CMOS single-chip 8-bit MCU with 12-bit A/D converter and LCD driver



A96R739

Datasheet

V 1.3

Main features

- **8-bit Microcontroller With High Speed 8051 CPU**
- **Basic MCU Function**
 - 48 Kbytes Flash Code Memory
 - 1280 bytes SRAM(IRAM 256 bytes + XRAM 1024 bytes)
- **Built-in Analog Function**
 - Power-On Reset and Low Voltage Detect Reset
 - Internal 8 MHz HFIRC Oscillator ($\pm 1.0\%$, $T_A = -10 \sim +55^\circ\text{C}$, User trim)
 - Internal 32 kHz LFIRC Oscillator ($\pm 5.0\%$, $T_A = -10 \sim +55^\circ\text{C}$)
 - Watchdog Timer RC Oscillator (5kHz)
- **Peripheral Features**
 - 12-bit Analog to Digital Converter (5 inputs)
 - LCD Driver (32 Segments x 8 Commons)
 - 16-bit CRC/Checksum Generator
 - Built-in Transistor for IR LED Drive
- **I/O and Packages**
 - 13 I/O, 46 Shared I/O with LCD signal
 - 64LQFP, 64QFN, 48LQFP, 48QFN
 - Pb-free package
- **Operating Conditions**
 - 1.8V to 5.5V Wide Voltage Range
 - -40°C to 85°C Temperature Range
- **Application**
 - Home appliance, Industrial Control

Revised 22 December, 2022

Revision history

| Version | Date | Revision list |
|---------|------------|---|
| 1.0 | 2017.11.27 | Published this book. |
| 1.1 | 2018.04.27 | Updated 64-Pin QFN-0909/48-Pin QFN-0707 package diagrams in Chapter 4. Package Diagram. |
| 1.2 | 2018.09.07 | Revised this book. Change Max and Min value of REM Output High Current in 7.11 DC Characteristics. Add Device Nomenclature. Add notes about External Interrupt register in Chapter 10.12.7 Register Description for Interrupt. More descriptions in Chapter 11.8.3 16-bit Capture Mode. Change Figure 11.31 16-Bit Capture Mode for Timer 3. Change Figure 11.34 16-Bit Timer 3 Block Diagram. Fix the typo. |
| 1.3 | 2022.12.22 | Modify a font |

Version 1.3

Published by FAE team

2022 ABOV Semiconductor Co. Ltd. all rights reserved.

Additional information of this manual may be served by ABOV Semiconductor offices in Korea or distributors.

ABOV Semiconductor reserves the right to make changes to any information here in at any time without notice.

The information, diagrams and other data in this manual are correct and reliable;

however, ABOV Semiconductor is in no way responsible for any violations of patents or other rights of the third party generated by the use of this manual.

1 Overview

1.1 Description

The A96R739 is advanced CMOS 8-bit microcontroller with 48 Kbytes of FLASH. This is powerful microcontroller which provides a highly flexible and cost effective solution to many embedded control applications. This provides the following features : 48 Kbytes of FLASH, 256 bytes of IRAM, 1024 bytes of XRAM, general purpose I/O, basic interval timer, watchdog timer, 8/16-bit timer/counter, carrier generation, watch timer, buzzer driving port, 12-bit A/D converter, LCD driver, 16-bit CRC/Checksum Generator, Built-in Transistor for I.R LED Drive, on-chip POR, LVR, LVI, on-chip oscillator and clock circuitry. The A96R739 also supports power down modes to reduce power consumption.

| Device Name | FLASH | IRAM | XRAM | ADC | I/O PORT | Package |
|-------------|-----------|-----------|------------|----------|----------|-------------|
| A96R739RL | 48 Kbytes | 256 bytes | 1024 bytes | 5 inputs | 59 | 64LQFP-1010 |
| A96R739RU | | | | 5 inputs | 59 | 64QFN-0909 |
| A96R739CL | | | | 2 inputs | 43 | 48LQFP-0707 |
| A96R739CU | | | | 2 inputs | 43 | 48QFN-0707 |

Table 1.1 Ordering Information of A96R739

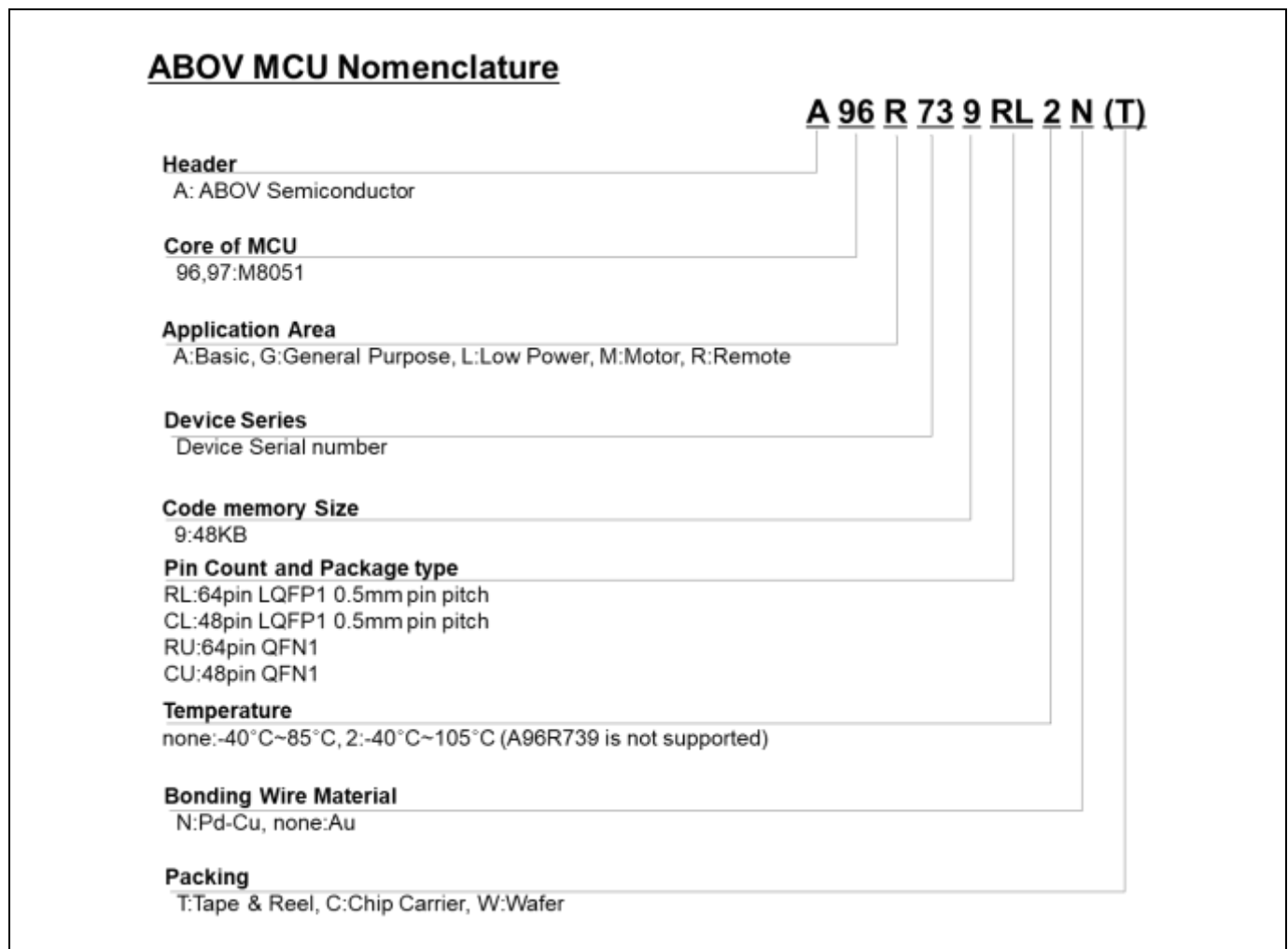

Figure 1.1 Device Nomenclature

1.2 Features

- **CPU**
 - 8-bit CISC core (M8051, 2 clocks per cycle)
- **ROM (FLASH) Capacity**
 - 48 Kbytes Flash with self read/write capability
 - On Chip debug and In-System Programming(ISP)
 - Endurance : 10,000 times(Sector 0~763)
100,000 times(Sector 764~767)
 - Retention : 10 years
- **256 bytes IRAM**
- **1024 bytes XRAM**
 - 38 bytes including LCD display RAM
- **General Purpose I/O (GPIO)**
 - Normal I/O : 13 Ports
(P4[7], P5[6:0], P6[4:0])
 - LCD shared I/O : 46 Ports
(P0[7:0], P1[7:0], P2[7:0], P3[6:0], P4[6:0], P7[7:0])
- **Basic Interval Timer (BIT)**
 - 8-bitx 1-ch
- **Watch Dog Timer (WDT)**
 - 8-bitx 1-ch
 - 5kHz internal RC oscillator
- **Timer/Counter**
 - 8-bitx 2-ch(T0/T1), 16-bitx 2-ch (T2/T3)
 - 16-bit Interval Timer x 1ch
- **Carrier Generation**
 - Carrier generation (by T1), T3 Clock source
- **Programmable Pulse Generation**
 - Pulse generation (by T2/T3)
 - 8-Bit PWM (by T0)
- **Watch Timer (WT)**
 - 3.91ms/0.25s/0.5s/1s/1min interval at 32.768kHz
- **Buzzer**
 - 8-bitx 1-ch
- **UART**
 - 8-bitx 1-ch
- **12-bit A/D Converter**
 - 5 Input channels
- **LCD Driver**
 - 32 Segments and 8 Common
 - 1/2, 1/3, 1/4, 1/5, 1/6, 1/8 duty selectable
 - Voltage booster and 16-step contrast control
- **16-Bit CRC/Checksum Generator**
 - Auto and User CRC/Checksum mode
- **Built-in Transistor for I.R LED Drive**
 - IOL = 630mA at 3V and VOL = 1.0V
- **Power On Reset**
 - Reset release level (1.4V)
- **Low Voltage Reset**
 - 14 level detect (1.60/2.05/2.15/2.25/2.37/2.50/2.65/2.82/ 3.01/ 3.22/3.47/3.76/4.10/4.51V)
- **Low Current Low Voltage Reset**
 - 1.80V ± 90mV, 0.9uA Operating Current
- **Low Voltage Indicator**
 - 13 level detect (2.05/2.15/2.25/2.37/2.50/2.65/2.82/ 3.01/ 3.22/ 3.47/ 3.76/ 4.10/ 4.51V)
- **Interrupt Sources**
 - External Interrupts
(EINT0 ~ EINT7, EINT10, EINT12, EINT13) (11)
 - Timer0/1/2/3 (5), Interval Timer (1)
 - WDT (1), BIT (1), WT (1)
 - ADC (1), UART (2), LVI (1)
- **Internal RC Oscillator**
 - HFIRC frequency:
8MHz ±1.0% (TA= -10 ~ +55°C, User trim)
 - LFIRC frequency:
32kHz ±5.0% (TA= -10 ~ +55°C)
- **Power Down Mode**
 - STOP, IDLE mode
- **Operating Voltage and Frequency**
 - 1.8V ~ 5.5V (@ 32 ~ 38kHz with SX-tal)
 - 2.0V ~ 5.5V (@ 0.4 ~ 4.2MHz with X-tal, Crystal)
 - 1.8V ~ 5.5V (@ 0.4 ~ 4.2MHz with X-tal, Ceramic)
 - 2.4V ~ 5.5V (@ 0.4 ~ 8.0MHz with X-tal)
 - 3.0V ~ 5.5V (@ 0.4 ~ 12.0MHz with X-tal)
 - 1.8V ~ 5.5V (@ 0.5MHz ~ 8MHz with HFIRC)
 - 1.8V ~ 5.5V (@ 4kHz ~ 32kHz with LFIRC)
 - Voltage dropout converter included for core
- **Minimum Instruction Execution Time**
 - 167ns (@12MHz main clock)
 - 61us (@ 32.768kHz sub clock)
- **Operating Temperature**
 - -40 ~ +85°C
- **Oscillator Type**
 - 0.4-12MHz Crystal or Ceramic for main clock
 - 32.768kHz Crystal for sub clock
- **Package Type**
 - 64-Pin LQFP-1010/48-Pin LQFP-0707
 - 64-Pin QFN-0909/48-Pin QFN-0707
 - Pb-free package

1.3 Development tools

1.3.1 Compiler

We do not provide the compiler. Please contact the third parties.

The core of A96R739 is Mentor 8051. And, device ROM size is smaller than 64k bytes. Developer can use all kinds of third party's standard 8051 compiler.

1.3.2 OCD(On-chip debugger) emulator and debugger

The OCD (On Chip Debug) emulator supports ABOV Semiconductor's 8051 series MCU emulation.

The OCD interface uses two-wire interfacing between PC and MCU which is attached to user's system. The OCD can read or change the value of MCU internal memory and I/O peripherals. And the OCD also controls MCU internal debugging logic, it means OCD controls emulation, step run, monitoring, etc.

The OCD Debugger program works on all Microsoft-Windows operating system.

If you want to see more details, please refer to OCD debugger manual. You can download debugger S/W and manual from our web-site(<http://www.abov.co.kr>).

Connection:

- DSCL (A96R739 P33 port)
- DSDA (A96R739 P32 port)

OCD connector diagram: Connect OCD with user system

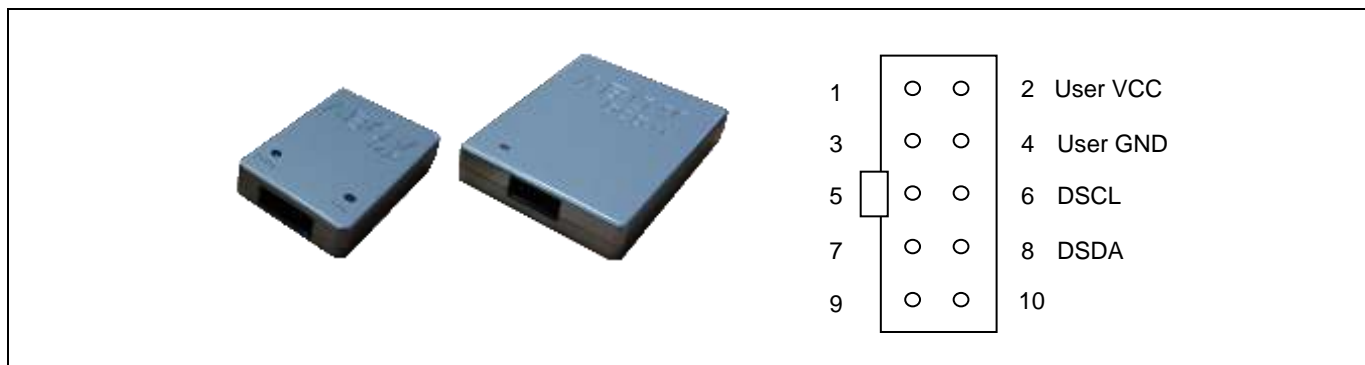

Figure 1.2 Debugger(OCD1/OCD2) and Pin description

1.3.3 Programmer

Single programmer :

E-PGM+ : It programs MCU device directly.

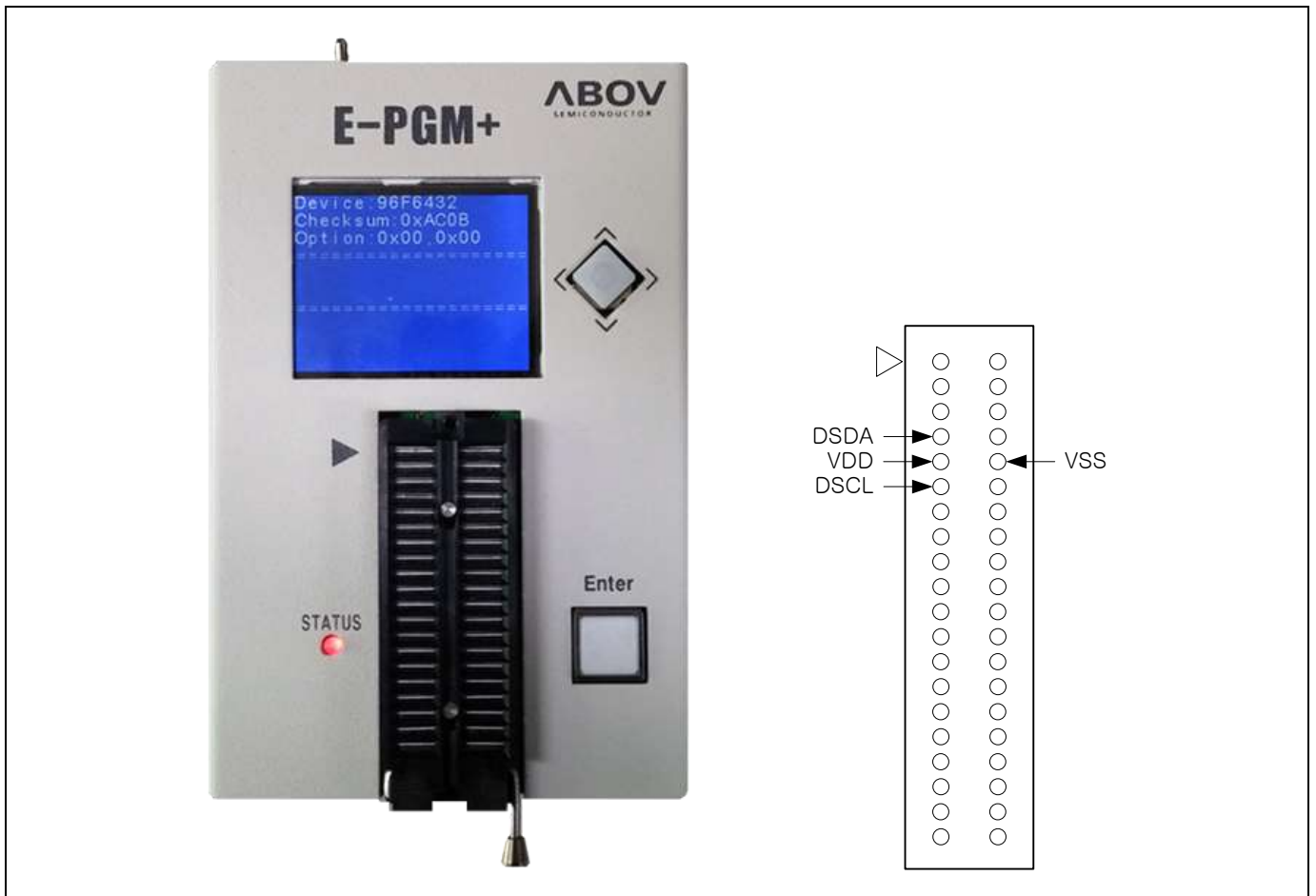

Figure 1.3 E-PGM+(Single writer)

OCD emulator:

It can write code to MCU device too, because OCD debugger supports ISP (In System Programming).It does not require additional H/W, except developer's target system.

Gang programmer: E-GANG4 and E-GANG6

- It can run PC controlled mode.
- It can run standalone without PC control too.
- USB interface is supported.
- Easy to connect to the handler.



Figure 1.4 E-GANG4 and E-GANG6 (for Mass Production)

1.4 MTP programming

1.4.1 Overview

The program memory of A96R739 is MTP Type. This flash is accessed by serial data format. There are four pins(DSCL, DSDA, VDD, VSS) for programming/reading the flash.

| Pin name | Main chip pin name | During programming | |
|----------|--------------------|--------------------|--|
| | | I/O | Description |
| DSCL | P33 | I | Serial clock pin. Input only pin. |
| DSDA | P32 | I/O | Serial data pin. Output port when reading and input port when programming. Can be assigned as input/push-pull output port. |
| VDD, VSS | VDD, VSS | - | Logic power supply pin. |

Table 1.2 Descriptions of pins which are used to programming/reading the Flash

1.4.2 On-Board programming

The A96R739 needs only four signal lines including VDD and VSS pins for programming FLASH with serial protocol. Therefore the on-board programming is possible if the programming signal lines are considered when the PCB of application board is designed.

1.4.3 Circuit Design Guide

At the FLASH programming, the programming tool needs 4 signal lines that are DSCL, DSDA, VDD and VSS. When you design the PCB circuits, you should consider the usage of these signal lines for the on-board programming. Please be careful to design the related circuit of these signal pins because rising/falling timing of DSCL and DSDA is very important for proper programming.

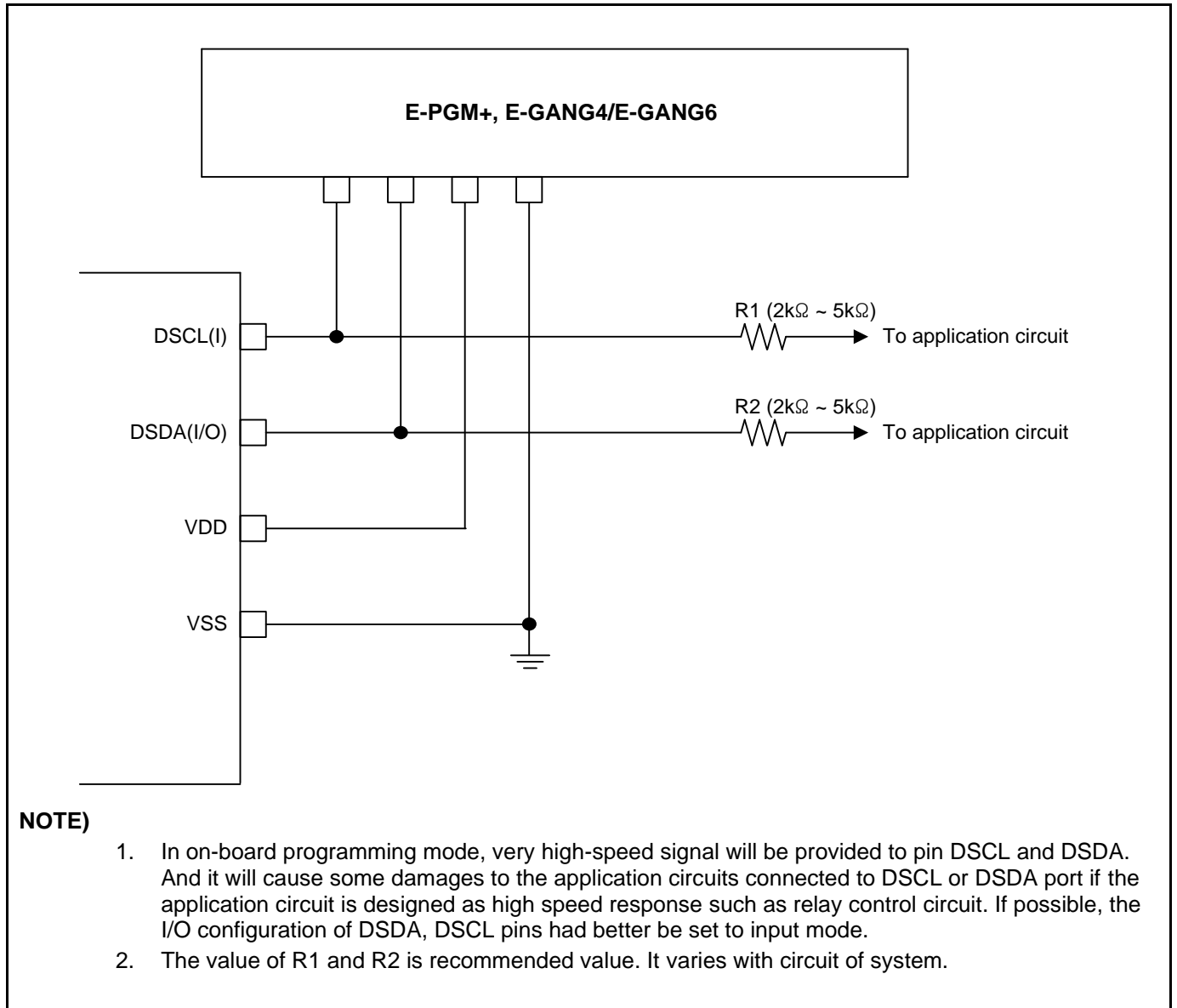

Figure 1.5 PCB design guide for on board programming

2 Block diagram

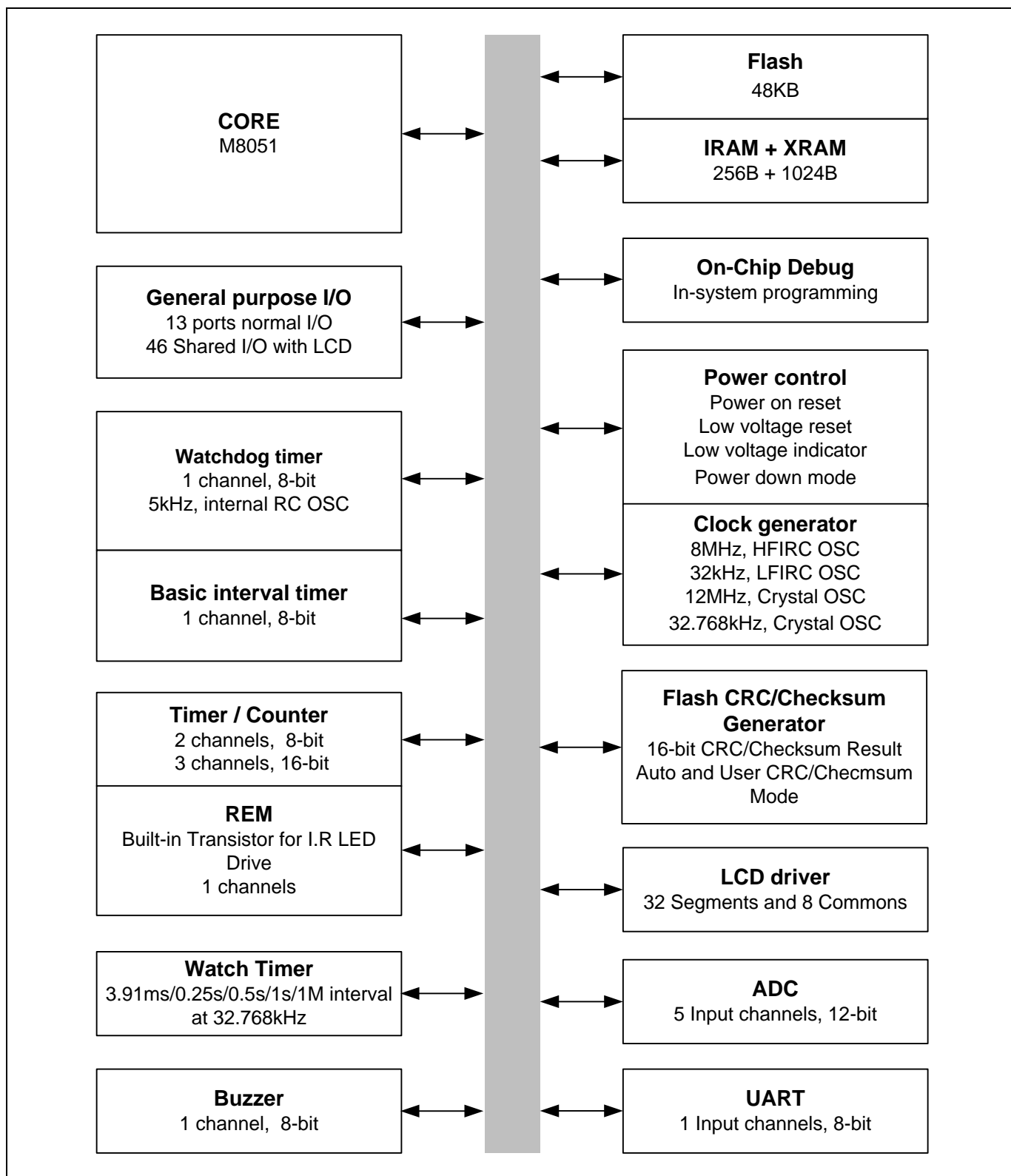

Figure 2.1 Block diagram of A96R739

3 Pin assignment

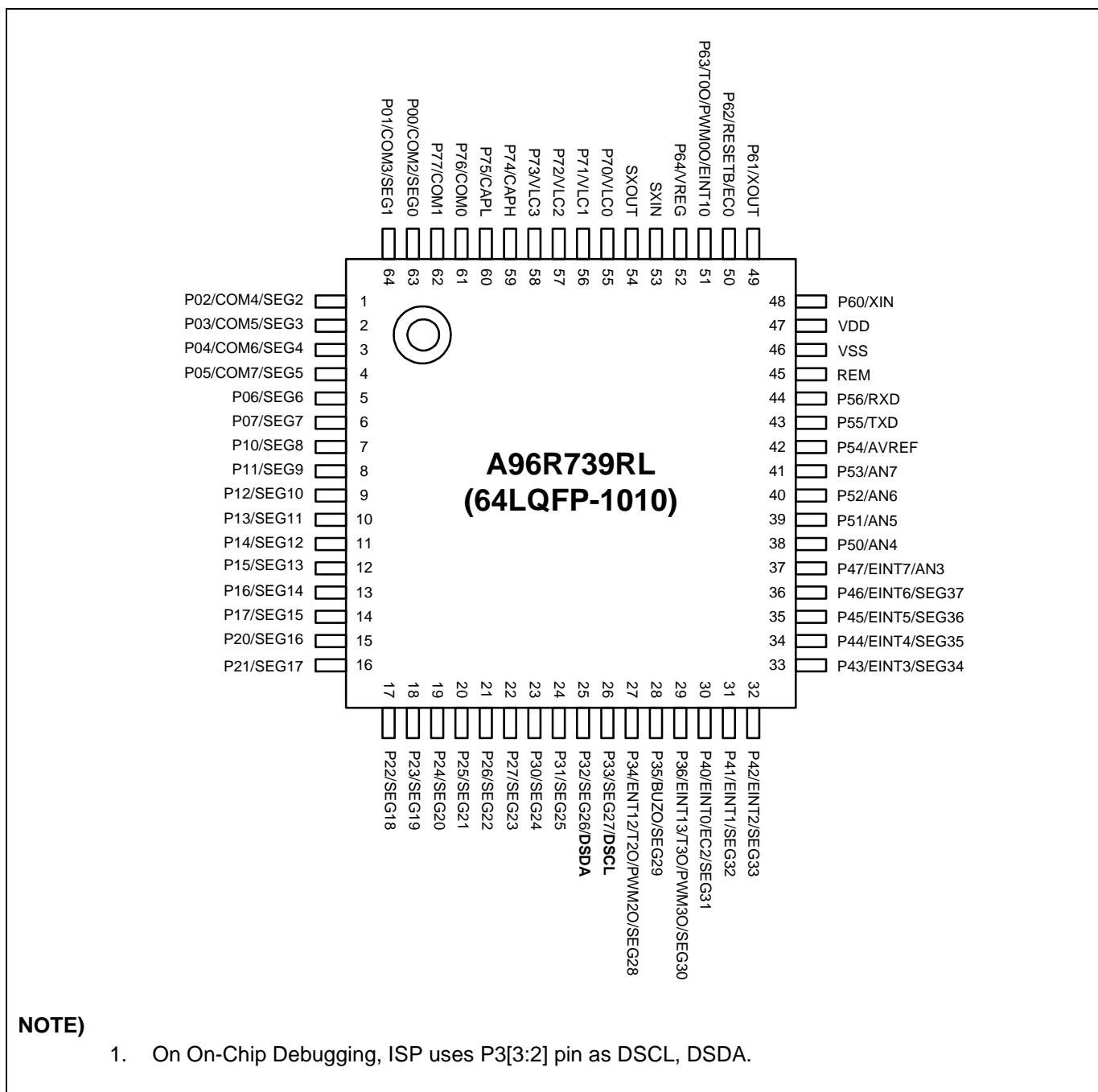
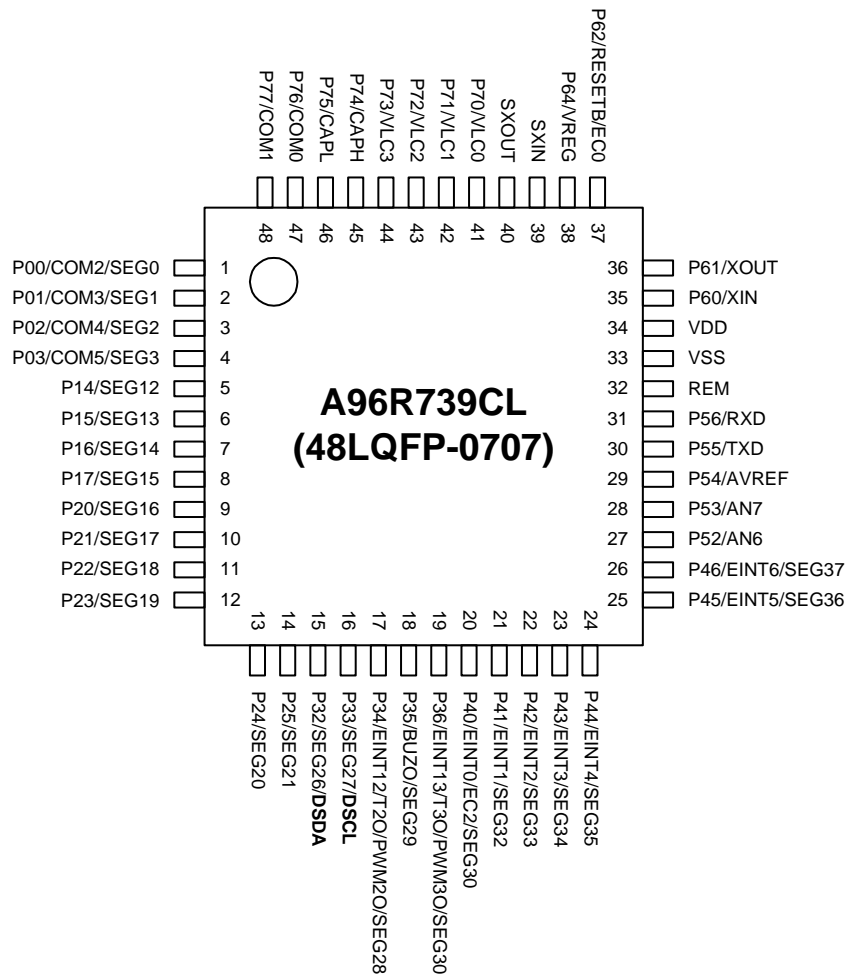

Figure 3.1 A96R739RL 64LQFP Pin Assignment



NOTE)

1. On On-Chip Debugging, ISP uses P3[3:2] pin as DSCL, DSDA.
2. The P04-P07, P10-P13, P26-P27, P30-P31, P47, P50-P51 and P63 pins should be selected as a push-pull output or an input with pull-up resistor by software control when the 48-pin package is used.

Figure 3.3 A96R739CL 48LQFP Pin Assignment

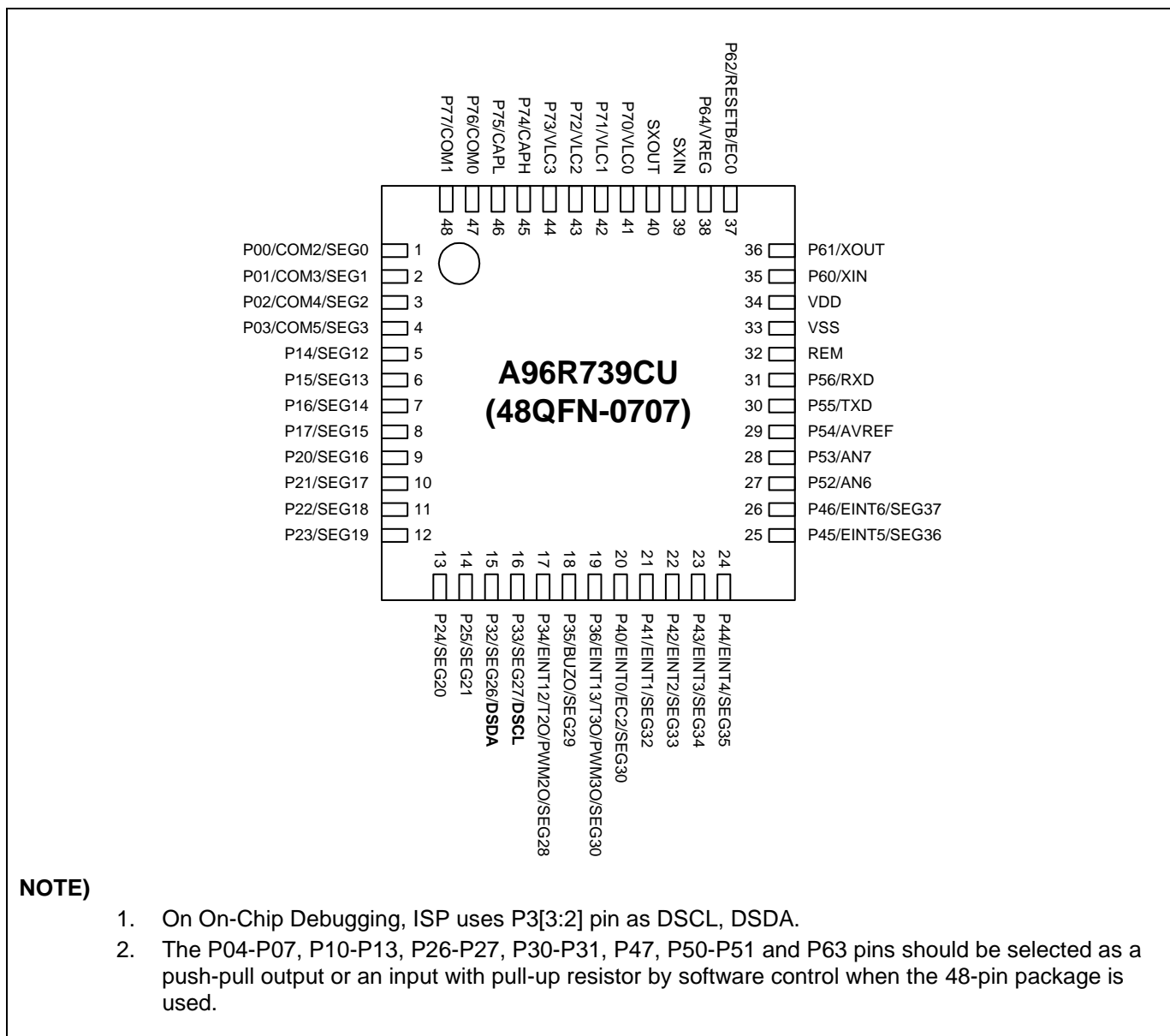

NOTE)

1. On On-Chip Debugging, ISP uses P3[3:2] pin as DSCL, DSDA.
2. The P04-P07, P10-P13, P26-P27, P30-P31, P47, P50-P51 and P63 pins should be selected as a push-pull output or an input with pull-up resistor by software control when the 48-pin package is used.

Figure 3.4 A96R739CU 48QFN Pin Assignment

4 Package Diagram

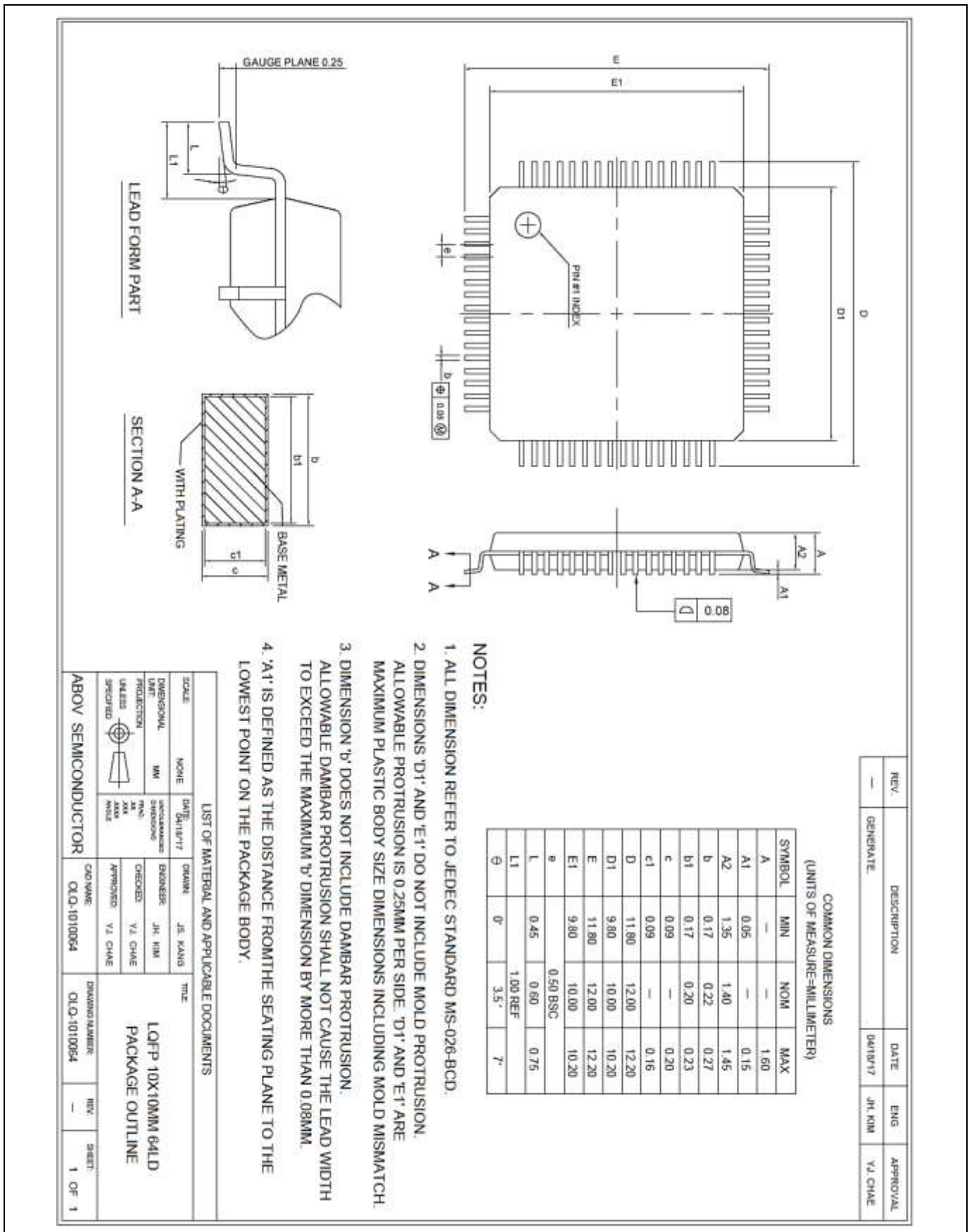

Figure 4.1 64-Pin LQFP-1010 Package

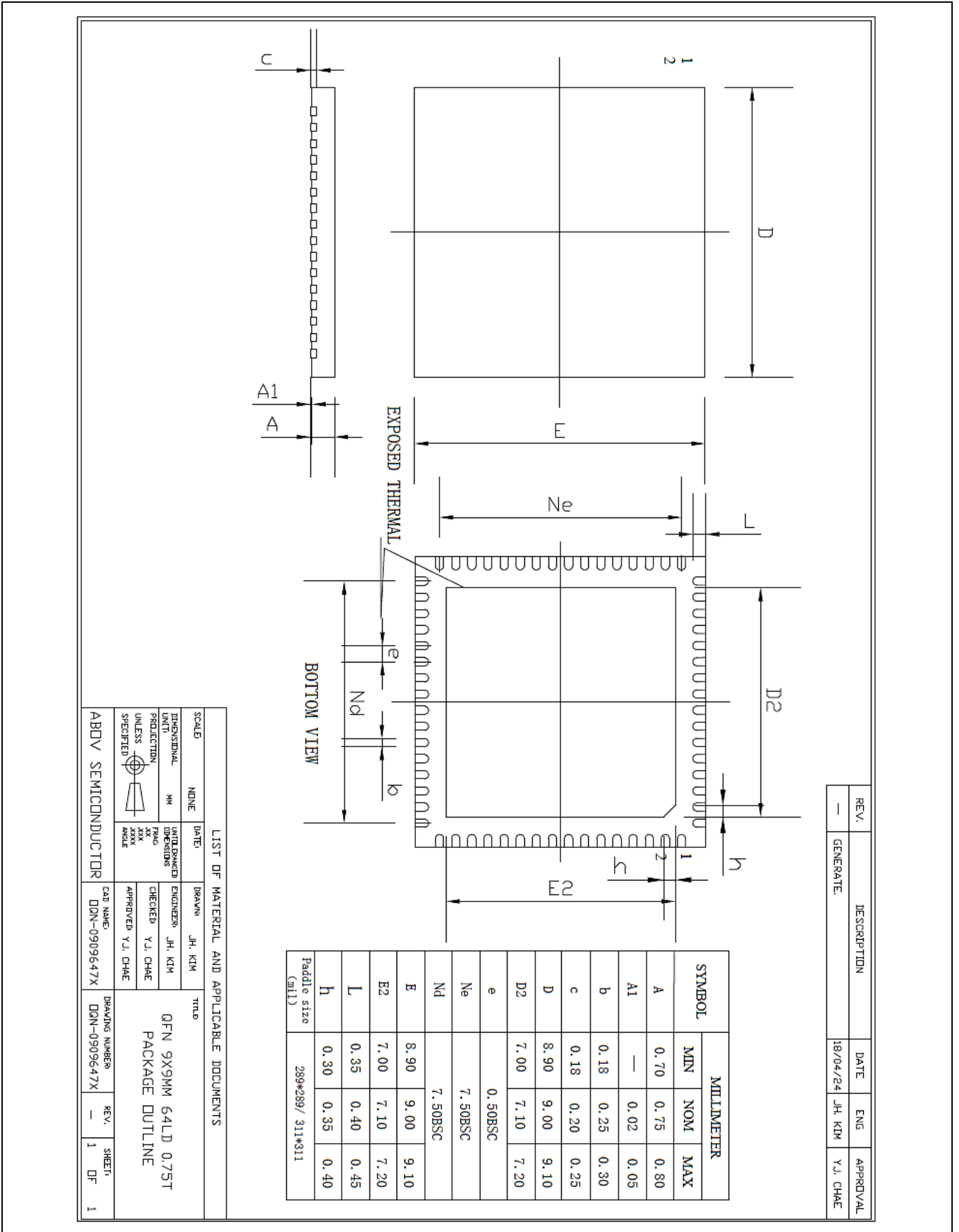

Figure 4.2

64-Pin QFN-0909 Package

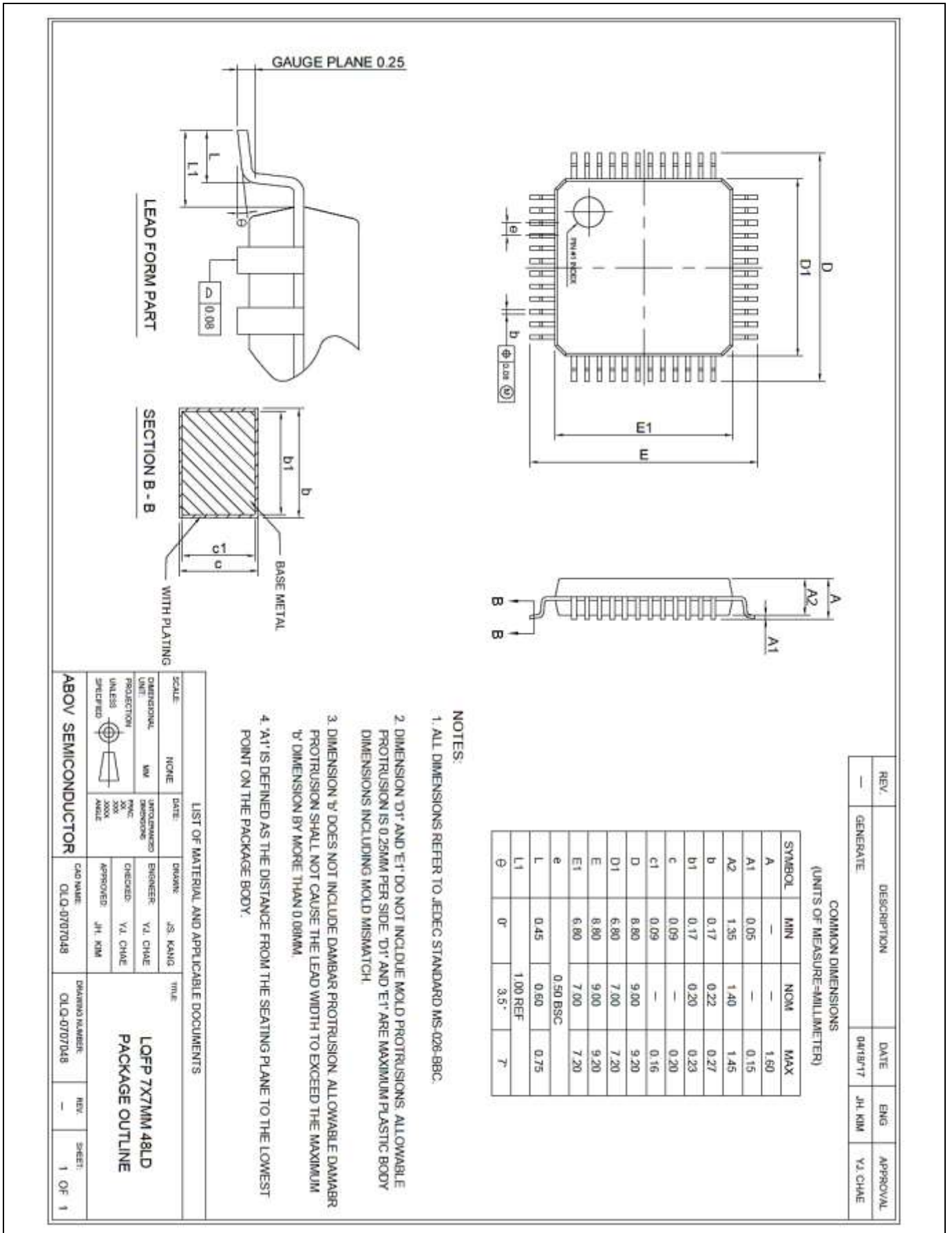

Figure 4.3

48-Pin LQFP-0707 Package

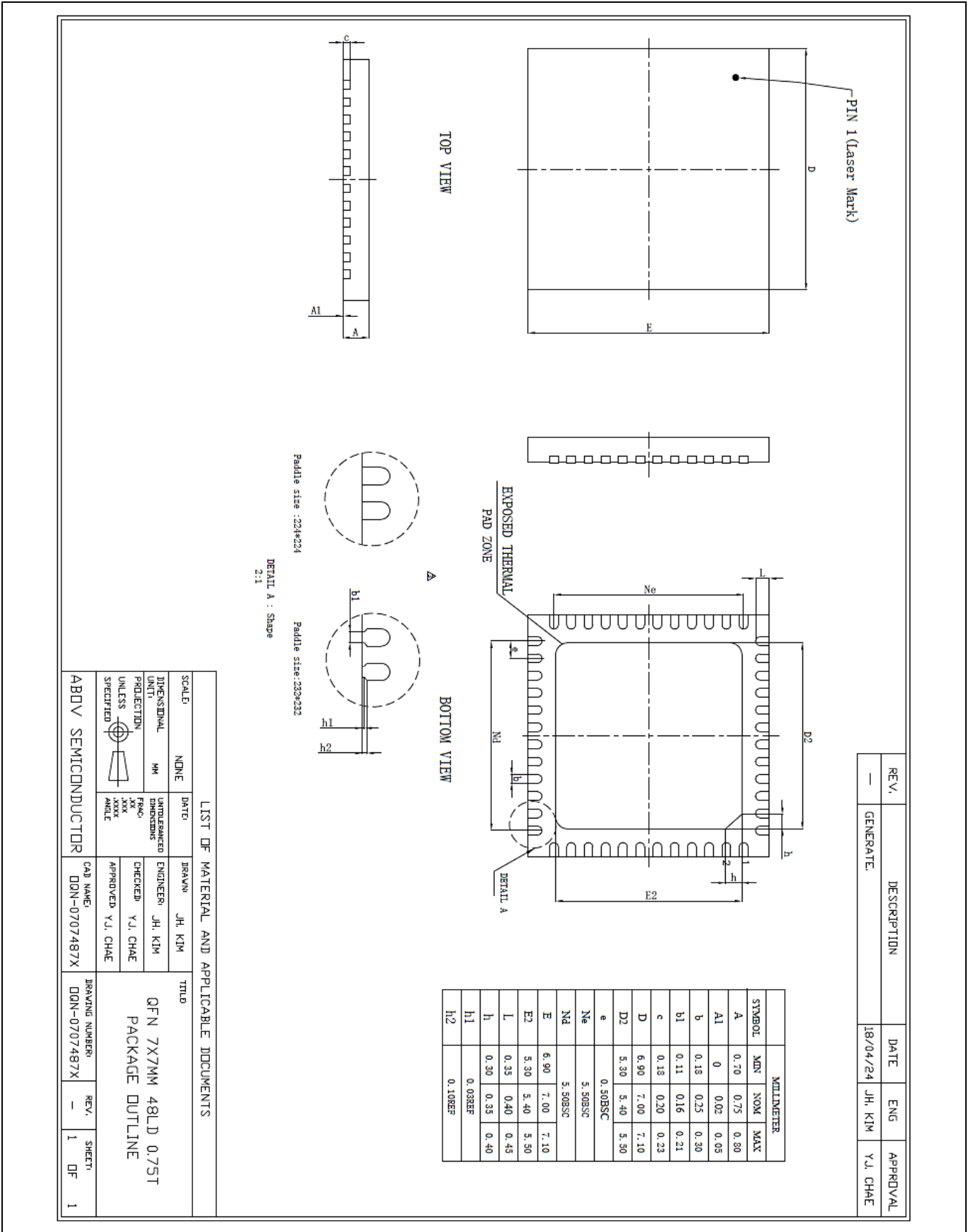

Figure 4.4

48-Pin QFN-0707 Package

5 Pin Description

| PIN Name | I/O | Function | @RESET | Shared with |
|----------|-------------|---|--------|------------------------|
| P00 | I/O | Port 0 is a bit-programmable I/O port which can be configured as an input, a push-pull output or an open-drain output. A pull-up resistor can be specified in 1-bit unit. The P04–P07 are not in the 48-Pin package. | Input | COM2/SEG0 |
| P01 | | | | COM3/SEG1 |
| P02 | | | | COM4/SEG2 |
| P03 | | | | COM5/SEG3 |
| P04 | | | | COM6/SEG4 |
| P05 | | | | COM7/SEG5 |
| P06 | | | | SEG6 |
| P07 | | | | SEG7 |
| P10 | I/O | Port 1 is a bit-programmable I/O port which can be configured as an input, a push-pull output, or an open-drain output. A pull-up resistor can be specified in 1-bit unit. The P10–P13 are not in the 48-Pin package. | Input | SEG8 |
| P11 | | | | SEG9 |
| P12 | | | | SEG10 |
| P13 | | | | SEG11 |
| P14 | | | | SEG12 |
| P15 | | | | SEG13 |
| P16 | | | | SEG14 |
| P17 | | | | SEG15 |
| P20 | I/O | Port 2 is a bit-programmable I/O port which can be configured as an input, a push-pull output, or an open-drain output. A pull-up resistor can be specified in 1-bit unit. The P26–P27 are not in the 48-Pin package. | Input | SEG16 |
| P21 | | | | SEG17 |
| P22 | | | | SEG18 |
| P23 | | | | SEG19 |
| P24 | | | | SEG20 |
| P25 | | | | SEG21 |
| P26 | | | | SEG22 |
| P27 | | | | SEG23 |
| P30 | I/O | Port 3 is a bit-programmable I/O port which can be configured as an input (P32 – P36: Schmitt trigger input), a push-pull output, or an open-drain output. A pull-up resistor can be specified in 1-bit unit. The P30–P31 are not in the 48-Pin package. | Input | SEG24 |
| P31 | | | | SEG25 |
| P32 | | | | SEG26/DSDA |
| P33 | | | | SEG27/DSCL |
| P34 | | | | ENIT12/T20/PWM20/SEG28 |
| P35 | | | | BUZO/SEG29 |
| P36 | | | | EINT13/T30/PWM30/SEG30 |
| P40 | | | | I/O |
| P41 | EINT1/SEG32 | | | |
| P42 | EINT2/SEG33 | | | |
| P43 | EINT3/SEG34 | | | |
| P44 | EINT4/SEG35 | | | |
| P45 | EINT5/SEG36 | | | |
| P46 | EINT6/SEG37 | | | |
| P47 | EINT7/AN3 | | | |

Table 5.1 Normal Pin Description

| PIN Name | I/O | Function | @RESET | Shared with |
|----------|-----|---|--------|------------------------|
| P50 | I/O | Port 5 is a bit-programmable I/O port which can be configured as a schmitt-trigger input, a push-pull output, or an open-drain output. A pull-up resistor can be specified in 1-bit unit. The P50–P51 is not in the 48-Pin package. | Input | AN4 |
| P51 | | | | AN5 |
| P52 | | | | AN6 |
| P53 | | | | AN7 |
| P54 | | | | AVREF |
| P55 | | | | TXD |
| P56 | | | | RXD |
| P60 | I/O | Port 6 is a bit-programmable I/O port which can be configured as a schmitt-trigger input, a push-pull output, or an open-drain output. A pull-up resistor can be specified in 1-bit unit. The P63 are not in the 48-Pin package. | Input | XIN |
| P61 | | | | XOUT |
| P62 | | | | RESETB/EC0 |
| P63 | | | | T00/PWM00/ENT10 |
| P64 | | | | VREG |
| P70 | I/O | Port 7 is a bit-programmable I/O port which can be configured as an input, a push-pull output, or an open-drain output. A pull-up resistor can be specified in 1-bit unit. | Input | VLC0 |
| P71 | | | | VLC1 |
| P72 | | | | VLC2 |
| P73 | | | | VLC3 |
| P74 | | | | CAPL |
| P75 | | | | CAPH |
| P76 | | | | COM0 |
| P77 | | | | COM1 |
| EINT10 | I/O | External interrupt and Timer 0 capture input | Input | P63/T00/PWM00 |
| EINT12 | I/O | External interrupt and Timer 2 capture input | Input | P34/T20/PWM20/SEG28 |
| EINT13 | I/O | External interrupt and Timer 3 capture input | Input | P36/T30/PWM30/SEG30 |
| EINT0 | I/O | External interrupt inputs | Input | P40/EC2/SEG31 |
| EINT1 | | | | P41/SEG32 |
| EINT2 | | | | P42/SEG33 |
| EINT3 | | | | P43/SEG34 |
| EINT4 | | | | P44/SEG35 |
| EINT5 | | | | P45/SEG36 |
| EINT6 | | | | P46/SEG37 |
| EINT7 | | | | P47/AN3 |
| T00 | I/O | Timer 0 interval output | Input | P63/PWM00/EINT10 |
| T20 | I/O | Timer 2 interval output | Input | P34/PWM20/ENIT12/SEG28 |
| T30 | I/O | Timer 3 interval output | Input | P36/PWM30/ENIT13/SEG30 |
| PWM00 | I/O | Timer 0 PWM output | Input | P63/T00/EINT10 |
| PWM20 | I/O | Timer 2 pulse output | Input | P34/T20/ENT12/SEG28 |
| PWM30 | I/O | Timer 3 pulse output | Input | P36/T30/ENT13/SEG30 |
| EC0 | I/O | Timer 0 event count input | Input | P62/RESETB |
| EC2 | I/O | Timer 2 event count input | Input | P40/EINT0/SEG31 |
| REM | O | High current n-channel open-drain output for driving I.R. LED. | Output | – |
| BUZO | I/O | Buzzer signal output | Input | P35/SEG29 |
| TXD | I/O | UART data output | Input | P55 |
| RXD | I/O | UART data input | Input | P56 |

Table 5.1 Normal Pin Description (Continued)

| PIN Name | I/O | Function | @RESET | Shared with |
|-------------|-----|---|--------|----------------------|
| AN3 | I/O | A/D converter analog input channels | Input | P47/EINT7 |
| AN4 | | | | P50 |
| AN5 | | | | P51 |
| AN6 | | | | P52 |
| AN7 | | | | P53 |
| VLC0–VLC3 | I/O | LCD bias voltage pins | Input | P70–P73 |
| CAPH | I/O | Capacitor terminals for voltage booster | Input | P74 |
| CAPL | | | Input | P75 |
| COM0 | I/O | LCD common signal outputs | Input | P76 |
| COM1 | | | | P77 |
| COM2 | | | | P00/SEG0 |
| COM3 | | | | P01/SEG1 |
| COM4 | | | | P02/SEG2 |
| COM5 | | | | P03/SEG3 |
| COM6 | | | | P04/SEG4 |
| COM7 | | | | P05/SEG5 |
| SEG0 | I/O | LCD segment signal outputs | Input | P00/COM2 |
| SEG1 | | | | P01/COM3 |
| SEG2 | | | | P02/COM4 |
| SEG3 | | | | P03/COM5 |
| SEG4 | | | | P04/COM6 |
| SEG5 | | | | P05/COM7 |
| SEG6 | | | | P06 |
| SEG7 | | | | P07 |
| SEG8–SEG15 | | | | P10–P17 |
| SEG16–SEG23 | | | | P20–P27 |
| SEG24 | | | | P30 |
| SEG25 | | | | P31 |
| SEG26 | | | | P32/DSDA |
| SEG27 | | | | P33/DSCL |
| SEG28 | | | | P34/EINT12/T2O/PWM2O |
| SEG29 | | | | P35/BUZO |
| SEG30 | | | | P36/EINT13/T3O/PWM3O |
| SEG31 | | | | P40/EINT0/EC2 |
| SEG32 | | | | P41/EINT1 |
| SEG33 | | | | P42/EINT2 |
| SEG34 | | | | P43/EINT3 |
| SEG35 | | | | P44/EINT4 |
| SEG36 | | | | P45/EINT5 |
| SEG37 | | | | P46/EINT6 |

Table 5.1 Normal Pin Description (Continued)

| PIN Name | I/O | Function | @RESET | Shared with |
|-------------|-----|--|--------|-------------|
| RESETB | I/O | System reset pin with a pull-up resistor when it is selected as the RESETB by "CONFIGURE OPTION" | Input | P62/EC0 |
| DSDA | I/O | On chip debugger data input/output | Input | P32/SEG26 |
| DSCL | I/O | On chip debugger clock input | Input | P33/SEG27 |
| XIN | I/O | Main oscillator pins | Input | P60 |
| XOUT | | | | P61 |
| SXIN, SXOUT | I/O | Sub oscillator pins | Input | – |
| VREG | I/O | Regulator voltage output for sub clock. 0.1uF capacitor needed. | Input | P64 |
| AVREF | I/O | A/D converter reference voltage | Input | P54 |
| VDD, VSS | – | Power input pins | – | – |

Table 5.1 Normal Pin Description (Concluded)

NOTE)

1. The P62/RESETB/EC0 pin is configured as one of the P62/EC0 and the RESETB pin by the "CONFIGURE OPTION".
2. If the P32/SEG26/DSDA and P33/SEG27/DSCL pins are connected to an emulator during reset or power-on reset, the pins are automatically configured as the debugger pins.
3. The P32/SEG26/DSDA and P33/SEG27/DSCL pins are configured as inputs with an internal pull-up resistor only during the reset or power-on reset.
4. The P60/XIN and P61/XOUT pins are configured as a function pin by software control.
5. The P64/VREG pins are configured as a function pin by software control.
6. The P64/VREG pin should be configured as a VREG alternative function if a sub oscillator is used.
7. The P04-P07, P10-P13, P26-P27, P30-P31, P47, P50-P51 and P63 are not in the 48-pin package.

6 Port Structures

6.1 General Purpose I/O Port

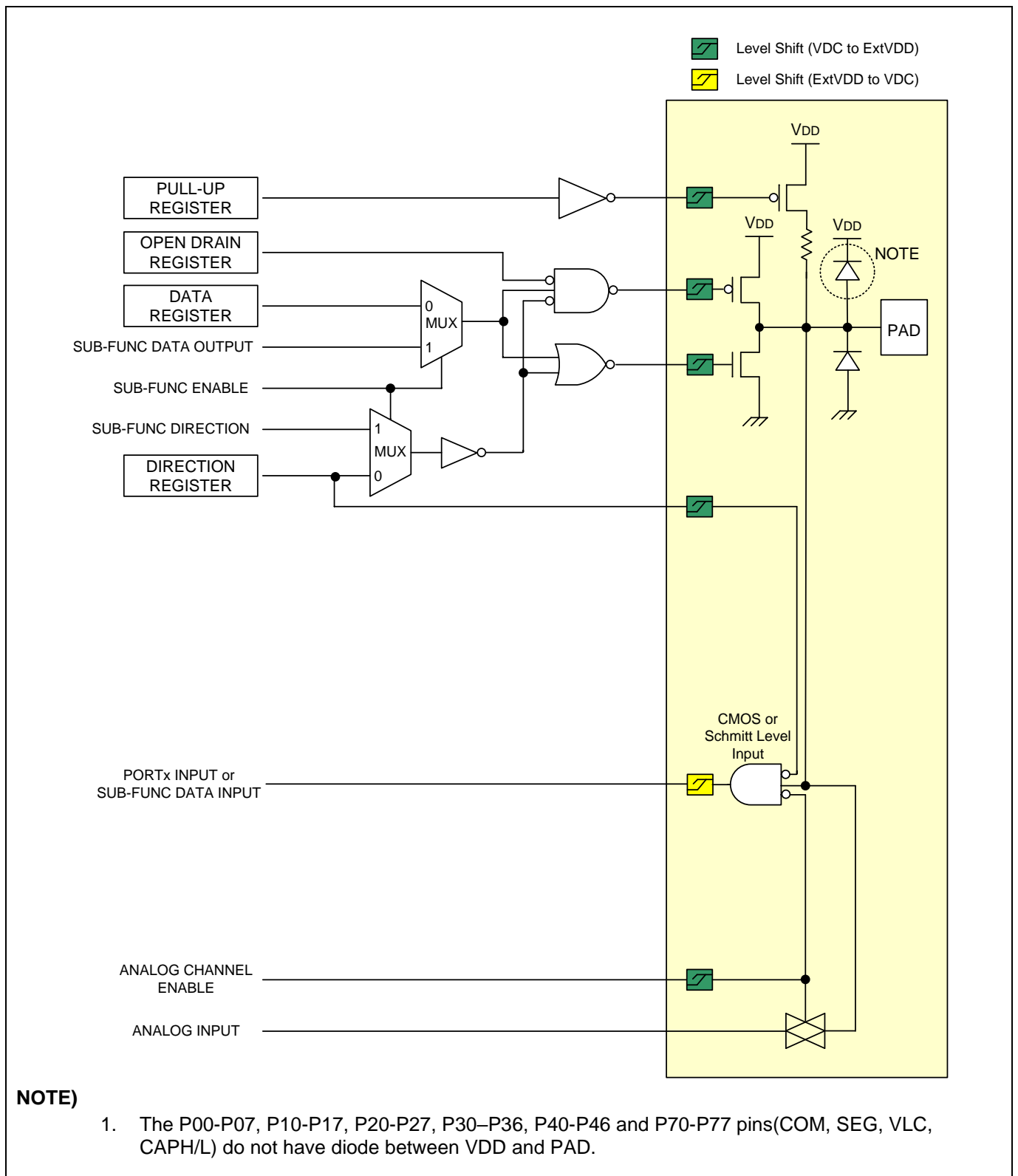

Figure 6.1 General Purpose I/O Port

6.2 External Interrupt I/O Port

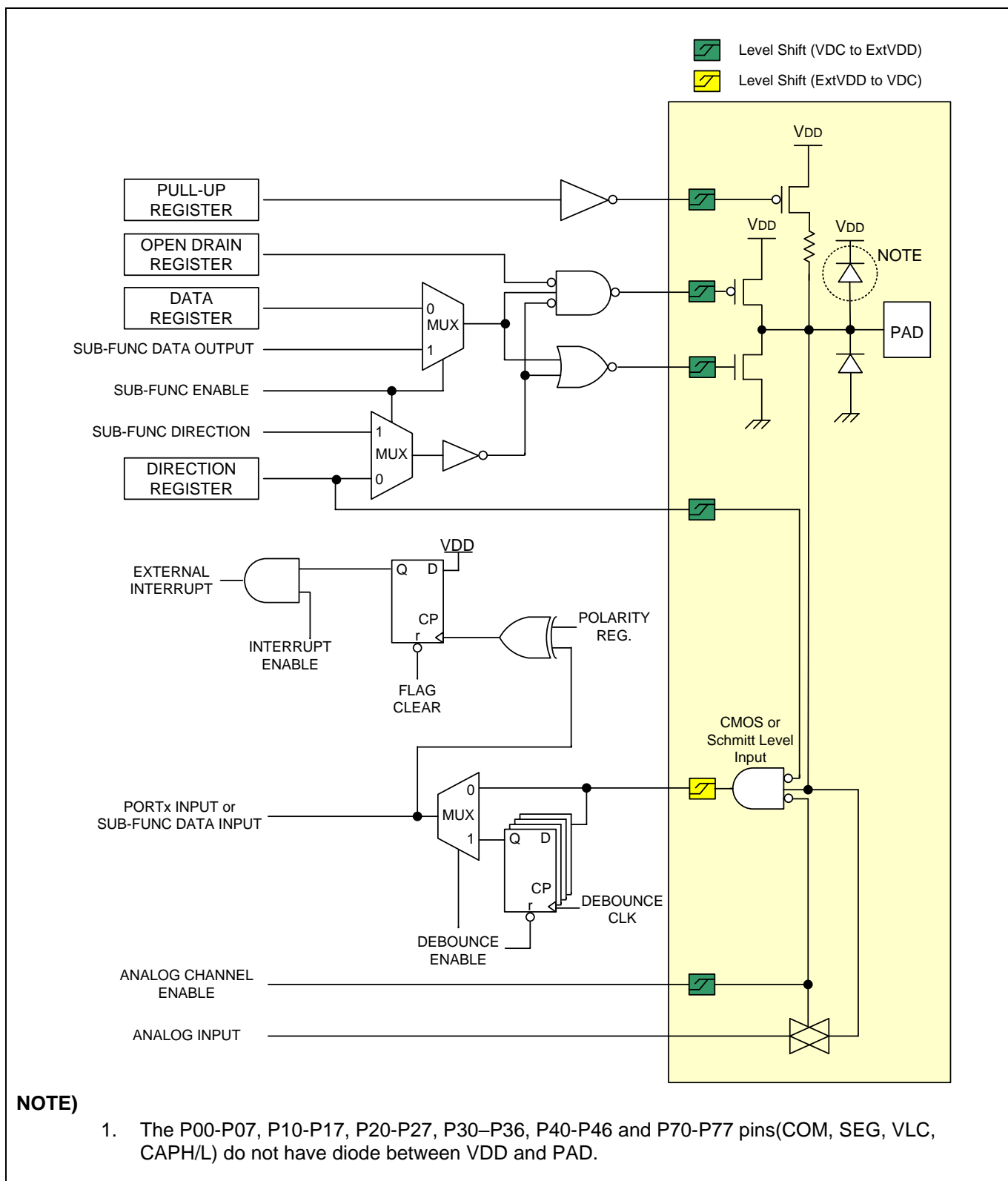

Figure 6.2 External Interrupt I/O Port

7 Electrical Characteristics

7.1 Absolute Maximum Ratings

| Parameter | Symbol | Ratings | Unit | Note |
|-------------------------|-------------------|----------------|------|---|
| Supply Voltage | VDD | -0.3 – +6.5 | V | – |
| Normal Pin | V _I | -0.3 – VDD+0.3 | V | Voltage on any pin with respect to V _{SS} |
| | V _O | -0.3 – VDD+0.3 | V | |
| | I _{OH} | -10 | mA | Maximum current output sourced by (I _{OH} per I/O pin) |
| | ∑ I _{OH} | -80 | mA | Maximum current (∑ I _{OH}) |
| | I _{OL} | 60 | mA | Maximum current sunk by (I _{OL} per I/O pin) |
| | ∑ I _{OL} | 120 | mA | Maximum current (∑ I _{OL}) |
| REM Output Pin | I _{OL} | 800 | mA | Maximum current sunk by REM pin |
| Total Power Dissipation | P _T | 600 | mW | – |
| Storage Temperature | T _{STG} | -65 – +150 | °C | – |

Table 7.1 Absolute Maximum Ratings

NOTE)

- Stresses beyond those listed under “Absolute Maximum Ratings” may cause permanent damage to the device. This is a stress rating only and functional operation of the device at any other conditions beyond those indicated in the operational sections of this specification is not implied. Exposure to absolute maximum rating conditions for extended periods may affect device reliability.

7.2 Recommended Operating Conditions

| Parameter | Symbol | Conditions | | (T _A =-40°C ~ +85°C) | | Units | |
|-----------------------|------------------|-------------------|--------|---------------------------------|-----|-------|-----|
| | | | | Min | Max | | |
| Operating Voltage | VDD | fx = 32 – 38kHz | SX-tal | 1.8 | 5.5 | V | |
| | | fx = 0.4 – 4.2MHz | X-tal | Ceramic | 1.8 | | 5.5 |
| | | | | Crystal | 2.0 | | 5.5 |
| | | fx = 0.4 – 8MHz | X-tal | 2.4 | 5.5 | | |
| | | fx = 0.4 – 12MHz | | 3.0 | 5.5 | | |
| | | fx = 0.5 – 8MHz | HFIRC | 1.8 | 5.5 | | |
| fx = 4.0 – 32kHz | LFIRC | 1.8 | 5.5 | | | | |
| Operating Temperature | T _{OPR} | VDD = 1.8 – 5.5V | | -40 | 85 | °C | |

Table 7.2 Recommended Operating Conditions

7.3 A/D Converter Characteristics

($T_A = -40^{\circ}\text{C} \sim +85^{\circ}\text{C}$, $V_{DD} = 1.8\text{V} \sim 5.5\text{V}$, $V_{SS} = 0\text{V}$)

| Parameter | Symbol | Conditions | Min | Typ | Max | Units | |
|---|------------------------------|--|-----------|-----|----------|---------------|---------------|
| Resolution | – | – | – | 12 | – | bit | |
| Integral Non-Linear | INL | AVREF=2.7V – 5.5V, $f_x=8\text{MHz}$ | – | – | ± 6 | LSB | |
| Differential Non-Linearity | DNL | | – | – | ± 1 | | |
| Top Offset Error | TOE | | – | – | ± 5 | | |
| Zero Offset Error | ZOE | | – | – | ± 5 | | |
| Conversion Time | t_{CONV} | AVREF=4.0V – 5.5V | 20 | – | – | us | |
| | | AVREF=3.0V – 5.5V | 30 | – | – | | |
| | | AVREF=2.7V – 5.5V | 60 | – | – | | |
| Analog Input Voltage | V_{AIN} | – | VSS | – | AVREF | V | |
| Analog Reference Voltage | AVREF | – | 1.8 | – | VDD | | |
| Band Gap Reference Value ⁽⁴⁾ | $V_{\text{AL}_{\text{BGR}}}$ | VDD=3.3V, $T_A=25^{\circ}\text{C}$, MSB align, 8 times average ⁽⁵⁾ , Internal Reference (REFSEL=0), Different from CNFMRR0/1 values and ADC result ("CNFMRR0/1" – "ADC result") | – | – | ± 50 | LSB | |
| A/DC Input Leakage Current | I_{AIN} | AVREF=5.12V | – | – | 10 | μA | |
| A/DC Current | I_{ADC} | Enable | VDD=5.12V | – | 1 | 2 | mA |
| | | Disable | | – | – | 0.1 | μA |

Table 7.3 A/D Converter Characteristics

NOTE)

1. Zero offset error is the difference between 000000000000 and the converted output for zero input voltage (VSS).
2. Top offset error is the difference between 111111111111 and the converted output for top input voltage (AVREF).
3. If AVREF is less than 2.7V, the resolution degrades by 1-bit whenever AVREF drops 0.1V. (@ADCLK = 0.5MHz, Under 2.7V resolution has no test.)
4. The CNFMRR0/1 register of XRAM has an AD/C result value which reads V_{BGR} voltage at VDD=3.3V. The CNFMRR0 has the value of ADCDRL[7:0] and CNFMRR1 has the value of ADCDRH[7:0].
5. It recommends to calculate 8 times average of remainder excluding minimum and maximum value.

7.4 Power-On Reset Characteristics

($T_A = -40^{\circ}\text{C} \sim +85^{\circ}\text{C}$, $V_{DD} = 1.8\text{V} \sim 5.5\text{V}$, $V_{SS} = 0\text{V}$)

| Parameter | Symbol | Conditions | Min | Typ | Max | Units |
|-------------------------|------------|-------------|------|-----|------|---------------|
| Reset Release Level | V_{POR} | - | - | 1.4 | - | V |
| Hysteresis | ΔV | - | - | 0.2 | - | V |
| VDD Voltage Rising Time | t_R | 0.5V – 2.0V | 0.05 | - | 30.0 | V/ms |
| POR Current | I_{POR} | - | - | 0.2 | - | μA |

Table 7.4 Power-on Reset Characteristics

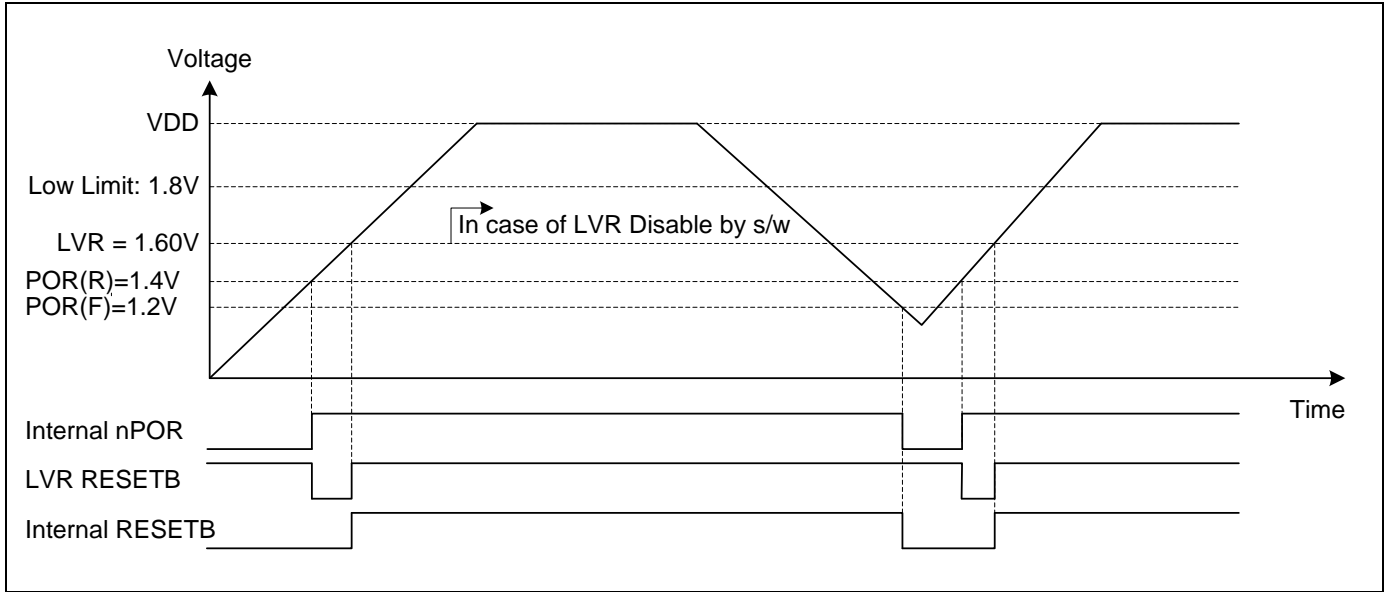

Figure 7.1 Power-on Reset Timing

7.5 Low Voltage Reset and Low Voltage Indicator Characteristics

(T_A=-40°C ~ +85°C, VDD=1.8V ~ 5.5V, VSS=0V)

| Parameter | Symbol | Conditions | Min | Typ | Max | Units | |
|---------------------|--------------------------------------|---|---------------------|--------|------|-------|----|
| Detection Level | V _{LVR} V _{LVI} | The LVR can select all levels but LVI can select other levels except 1.60V. | - | 1.60 | 1.79 | V | |
| | | | 1.90 | 2.05 | 2.20 | | |
| | | | 2.00 | 2.15 | 2.30 | | |
| | | | 2.10 | 2.25 | 2.40 | | |
| | | | 2.22 | 2.37 | 2.52 | | |
| | | | 2.35 | 2.50 | 2.65 | | |
| | | | 2.45 | 2.65 | 2.85 | | |
| | | | 2.62 | 2.82 | 3.02 | | |
| | | | 2.81 | 3.01 | 3.21 | | |
| | | | 3.02 | 3.22 | 3.42 | | |
| | | | 3.27 | 3.47 | 3.67 | | |
| | | | 3.46 | 3.76 | 4.06 | | |
| | | | 3.80 | 4.10 | 4.40 | | |
| | | | 4.21 | 4.51 | 4.81 | | |
| LVR Hysteresis | ΔV | - | - | 50 | 150 | mV | |
| LVI Hysteresis | ΔV | - | - | 10 | 100 | | |
| Minimum Pulse Width | t _{LW} | - | 100 | - | - | us | |
| LVR and LVI Current | I _{BL} | Enable (Both) | VDD=3V, Run mode | - | 14.0 | 24.0 | uA |
| | | Enable (One of two) | | - | 10.0 | 18.0 | |
| | | Disable (Both) | | VDD=3V | - | - | |

Table 7.5 LVR and LVI Characteristics

7.6 Low Current Low Voltage Reset Characteristics

(T_A=-40°C ~ +85°C, VDD=1.8V ~ 5.5V, VSS=0V)

| Parameter | Symbol | Conditions | Min | Typ | Max | Units |
|-----------------|------------------|-------------------------------------|------|------|------|-------|
| Detection Level | V _{LVR} | T _A = - 10 °C to + 55 °C | 1.71 | 1.80 | 1.89 | V |
| Hysteresis | ΔV | - | - | 25 | 100 | mV |
| LVR Current | I _{BL} | VDD=3V, T _A = 25 °C | - | 0.9 | 1.5 | uA |

Table 7.6 Low Current LVR Characteristics

7.7 High Frequency Internal RC Oscillator Characteristics

(T_A=-40°C ~ +85°C, VDD=1.8V ~ 5.5V, VSS=0V)

| Parameter | Symbol | Conditions | Min | Typ | Max | Units | |
|--------------------|--------------------|---|-----------------------------|------|-----|-------|---|
| Frequency | f _{HFIRC} | VDD = 2.0V – 5.5V | – | 8 | – | MHz | |
| Tolerance | – | T _A = -10 °C to + 55°C | With 0.1uF bypass capacitor | -2.0 | – | +2.0 | % |
| | | T _A = - 20 °C to + 85°C | | -3.0 | – | +3.0 | |
| | | T _A = - 40 °C to + 85°C | | -4.0 | – | +4.0 | |
| | | T _A = -10 °C to + 55°C (User trim, Using only E-PGM +) | | -1.0 | – | +1.0 | |
| Clock duty ratio | TOD | – | 40 | 50 | 60 | % | |
| Stabilization Time | t _{HFS} | – | – | – | 100 | us | |
| HFIRC Current | I _{HFIRC} | Enable | – | 0.2 | – | mA | |
| | | Disable | – | – | 0.1 | uA | |

Table 7.7 High Frequency Internal RC Oscillator Characteristics

NOTE)

1. User Trimming means the calibration of HFIRC frequency. Using E-PGM +.
2. To ensure ±1.0% tolerance of HFIRC frequency, it is necessary to do User Trimming.
3. Guaranteed by design, but might be On-Board programming after SMT process.
(HFIRC Calibration with high temperature can cause the shift of the frequency, be sure to calibrate Enough to cool to near room temperature after SMT process)

7.8 Low Frequency Internal RC Oscillator Characteristics

(T_A=-40°C ~ +85°C, VDD=1.8V ~ 5.5V, VSS=0V)

| Parameter | Symbol | Conditions | Min | Typ | Max | Units | |
|--------------------|--------------------|-----------------------------------|-----------------------------|------|-----|-------|----|
| Frequency | f _{LFIRC} | VDD = 2.0V – 5.5V | – | 32 | – | kHz | |
| Tolerance | – | T _A = -10 °C to + 55°C | With 0.1uF bypass capacitor | -5.0 | – | +5.0 | % |
| Clock duty ratio | TOD | – | | 40 | 50 | 60 | |
| Stabilization Time | t _{LFS} | – | – | – | 1 | ms | |
| LFIRC Current | I _{LFIRC} | Enable | VDD=5V | – | 5 | – | uA |
| | | Disable | | – | – | 0.1 | |

Table 7.8 Low Frequency Internal RC Oscillator Characteristics

7.9 Internal Watch-Dog Timer RC Oscillator Characteristics

(T_A=-40°C ~ +85°C, VDD=1.8V ~ 5.5V, VSS=0V)

| Parameter | Symbol | Conditions | Min | Typ | Max | Units |
|--------------------|--------------------|------------|-----|-----|-----|-------|
| Frequency | f _{WDTRC} | – | 2 | 5 | 10 | kHz |
| Stabilization Time | t _{WDTS} | – | – | – | 1 | ms |
| WDTRC Current | I _{WDTRC} | Enable | – | 1 | – | uA |
| | | Disable | – | – | 0.1 | |

Table 7.9 Internal WDTRC Oscillator Characteristics

7.10 LCD Voltage Characteristics

(T_A= -40°C ~ +85°C, VDD=2.0V ~ 5.5V, VSS= 0V)

| Parameter | Symbol | Conditions | Min | Typ | Max | Units | |
|-----------------------------|---|---|----------|--------------|----------|-------|--|
| LCD Voltage | V _{LC3} | Voltage booster enabled, 1/2 bias | Typx0.93 | 1.0+(Nx0.05) | Typx1.07 | V | |
| | | Voltage booster enabled, 1/3 and 1/4 bias | Typx0.93 | Typx1.07 | 0.75 | | |
| | | | | | 0.79 | | |
| | | | | | 0.83 | | |
| | | | | | 0.86 | | |
| | | | | | 0.90 | | |
| | | | | | 0.94 | | |
| | | | | | 0.98 | | |
| | | | | | 1.01 | | |
| | | | | | 1.05 | | |
| | | | | | 1.09 | | |
| | | | | | 1.13 | | |
| | | | | | 1.16 | | |
| | | | | | 1.20 | | |
| 1.24 | | | | | | | |
| 1.28 | | | | | | | |
| 1.31 | | | | | | | |
| LCD Mid Bias Voltage | V _{LC0/1/2} | Voltage booster enabled, 1/2 bias, No panel load, VDD=3V | Typx0.9 | 2xVLC3 | Typx1.1 | V | |
| | V _{LC0/1} | Voltage booster enabled, 1/3 bias, No panel load, VDD=3V | Typx0.9 | 3xVLC3 | Typx1.1 | | |
| | V _{LC2} | Voltage booster enabled, 1/3 bias, No panel load, VDD=3V | Typx0.9 | 2xVLC3 | Typx1.1 | | |
| | V _{LC0} | Voltage booster enabled, 1/4 bias, No panel load, VDD=3V | Typx0.9 | 4xVLC3 | Typx1.1 | | |
| | V _{LC1} | Voltage booster enabled, 1/4 bias, No panel load, VDD=3V | Typx0.9 | 3xVLC3 | Typx1.1 | | |
| | V _{LC2} | Voltage booster enabled, 1/4 bias, No panel load, VDD=3V | Typx0.9 | 2xVLC3 | Typx1.1 | | |
| | V _{LC1} | Voltage booster disabled, LCD dividing resistor, VDD=2.7V to 5.5V, 1/4 bias, LCD clock = 0Hz, V _{LC0} =VDD | Typ-0.2 | 0.75xVDD | Typ+0.2 | V | |
| | V _{LC2} | Voltage booster disabled, LCD dividing resistor, VDD=2.7V to 5.5V, 1/4 bias, LCD clock = 0Hz, V _{LC0} =VDD | Typ-0.2 | 0.5xVDD | Typ+0.2 | | |
| V _{LC3} | Voltage booster disabled, LCD dividing resistor, VDD=2.7V to 5.5V, 1/4 bias, LCD clock = 0Hz, V _{LC0} =VDD | Typ-0.2 | 0.25xVDD | Typ+0.2 | | | |
| LCD Driver Output Impedance | R _{LO} | V _{LCD} =3V, I _{LOAD} =±10uA | - | 5 | 10 | kΩ | |
| LCD Bias Dividing Resistor | R _{LCD1} | Internal resistor mode, T _A = 25°C | 20 | 30 | 40 | kΩ | |
| | R _{LCD2} | | 40 | 60 | 80 | | |
| | R _{LCD3} | | 80 | 120 | 160 | | |
| LCD Block Current | I _{LCD} | Voltage booster mode, VDD=3V, V _{LCD} =3.15V, 1/3Bias | - | 3 | 6 | uA | |

Table 7.10 LCD Voltage Characteristics

NOTE)

- Where N is the value of LCDCCR register (N = 0 to 15).

7.11 DC Characteristics

(TA= -40°C ~ +85°C, VDD=1.8V ~ 5.5V, VSS= 0V, fXIN= 12MHz)

| Parameter | Symbol | Conditions | Min | Typ | Max | Units | |
|----------------------------|------------------|--|----------------|------|--------|-------|----|
| Input High Voltage | V _{IH1} | P32-P36, P4, P5, P6, RESETB | 0.8VDD | – | VDD | V | |
| | V _{IH2} | All input pins except V _{IH1} | 0.7VDD | – | VDD | | |
| Input Low Voltage | V _{IL1} | P32-P36, P4, P5, P6, RESETB | – | – | 0.2VDD | V | |
| | V _{IL2} | All input pins except V _{IL1} | – | – | 0.3VDD | | |
| Output High Voltage | V _{OH} | VDD=4.5V, I _{OH} = – 2mA; All output ports except REM pin | VDD-1.0 | – | – | V | |
| Output Low Voltage | V _{OL} | VDD=4.5V, I _{OL} =15mA; All output ports except REM pin | – | – | 1.0 | V | |
| Output High Current | I _{OH} | VDD=4.5V, V _{OH} = 3.5V; All output ports except REM pin | -2 | – | – | mA | |
| Output Low Current | I _{OL} | VDD=4.5V, V _{OL} = 1.0V; All output ports except REM pin | 15 | – | – | mA | |
| REM Output High Current | I _{OH1} | VDD=3.0V, V _{OH} =2.0V, ROTs=1 | – | -10 | -5 | mA | |
| REM Output Low Current | I _{OL1} | VDD=3.0V, V _{OL} =1.0V, TA=25°C | ROTS=1 | 2.5 | 5.0 | – | mA |
| | I _{OL2} | | ROTS=0, RIOL=3 | 470 | 630 | – | |
| Input high leakage current | I _{IH} | All Input ports | – | – | 1 | uA | |
| Input low leakage current | I _{IL} | All Input ports | -1 | – | – | uA | |
| Pull-up resistor | R _{PU1} | V _I =0V, TA=25°C, All Input ports | VDD=5V | 50 | 80 | 110 | kΩ |
| | | | VDD=3V | 100 | 155 | 210 | |
| | R _{PU2} | V _I =0V, TA=25°C, RESETB | VDD=5V | 150 | 250 | 400 | |
| | | | VDD=3V | 300 | 500 | 700 | |
| OSC feedback resistor | R _{X1} | XIN=VDD, XOUT=VSS TA=25°C, VDD=5V FBS = 0 (Configure Option 2 : 3FH) | 600 | 1200 | 2000 | kΩ | |
| | | XIN=VDD, XOUT=VSS TA=25°C, VDD=5V FBS = 1 (Configure Option 2 : 3FH) | 250 | 500 | 750 | | |
| | R _{X2} | SXIN=VDD, SXOUT=VSS TA=25°C, VDD=5V | 2500 | 5000 | 10000 | kΩ | |

Table 7.11 DC Characteristics

7.11 DC Characteristics (Continued)

($T_A = -40^{\circ}\text{C} \sim +85^{\circ}\text{C}$, $V_{DD} = 1.8\text{V} \sim 5.5\text{V}$, $V_{SS} = 0\text{V}$, $f_{XIN} = 12\text{MHz}$)

| Parameter | Symbol | Conditions | Min | Typ | Max | Units | |
|----------------------------|--|---|------------------------|-----|------|-------|----|
| Supply current | I_{DD1} (Run) | $f_{XIN} = 12\text{MHz}$, $V_{DD} = 5\text{V} \pm 10\%$ | – | 3.0 | 6.0 | mA | |
| | | $f_{XIN} = 8\text{MHz}$, $V_{DD} = 3\text{V} \pm 10\%$ | – | 2.0 | 4.0 | | |
| | | $f_{HFIRC} = 8\text{MHz}$, $V_{DD} = 5\text{V} \pm 10\%$ | – | 2.0 | 4.0 | | |
| | I_{DD2} (Idle) | $f_{XIN} = 12\text{MHz}$, $V_{DD} = 5\text{V} \pm 10\%$ | – | 2.0 | 4.0 | mA | |
| | | $f_{XIN} = 8\text{MHz}$, $V_{DD} = 3\text{V} \pm 10\%$ | – | 1.0 | 2.0 | | |
| | | $f_{HFIRC} = 8\text{MHz}$, $V_{DD} = 5\text{V} \pm 10\%$ | – | 1.0 | 2.0 | | |
| | I_{DD3} (Run) | $f_{SUB} = 32.768\text{kHz}$ | VDD=3V±10%, TA=25°C | – | 90.0 | 180.0 | uA |
| | | $f_{LFIRC} = 32\text{kHz}$ | | – | 90.0 | 180.0 | |
| | I_{DD4} (Idle) | $f_{SUB} = 32.768\text{kHz}$ | VDD=3V±10%, TA=25°C | – | 4.0 | 8.0 | uA |
| $f_{LFIRC} = 32\text{kHz}$ | | – | | 6.0 | 12.0 | | |
| I_{DD5} | Stop, $V_{DD} = 3\text{V} \pm 10\%$, $T_A = 25^{\circ}\text{C}$ | | – | 0.5 | 2.7 | uA | |

Table 7.11 DC Characteristics (Continued)

NOTE)

1. Where the f_{XIN} is an external main oscillator, the f_{SUB} is an external sub oscillator, the f_{HFIRC} is an internal high frequency RC oscillator, the f_{LFIRC} is an internal low frequency RC oscillator and the f_x is the selected system clock.
2. All supply current items don't include the current of an internal Watch-dog timer RC (WDTRC) oscillator and a peripheral block.
3. All supply current items include the current of the power-on reset (POR) block.

7.12 AC Characteristics

($T_A = -40^{\circ}\text{C} \sim +85^{\circ}\text{C}$, $V_{DD} = 1.8\text{V} \sim 5.5\text{V}$)

| Parameter | Symbol | Conditions | Min | Typ | Max | Units |
|--|------------------------|--|-----|-----|-----|-------|
| RESETB input low width | t_{RST} | $V_{DD} = 5\text{V}$ | 10 | – | – | us |
| Interrupt Input High, Low width | t_{IWH}, t_{IWL} | All interrupts, $V_{DD} = 5\text{V}$ | 200 | – | – | ns |
| External Counter Input High, Low Pulse Width | t_{ECWH}, t_{ECWL} | $EC_n, V_{DD} = 5\text{V}$ ($n=0, 2$) | 200 | – | – | |
| External Counter Transition Time | t_{REC}, t_{FEC} | $EC_n, V_{DD} = 5\text{V}$ ($n=0, 2$) | 20 | – | – | |
| REM port High, Low width | t_{REMWH}, t_{REMWL} | REM, $V_{DD} = 5\text{V}$ | 5 | – | – | us |

Table 7.12 AC Characteristics

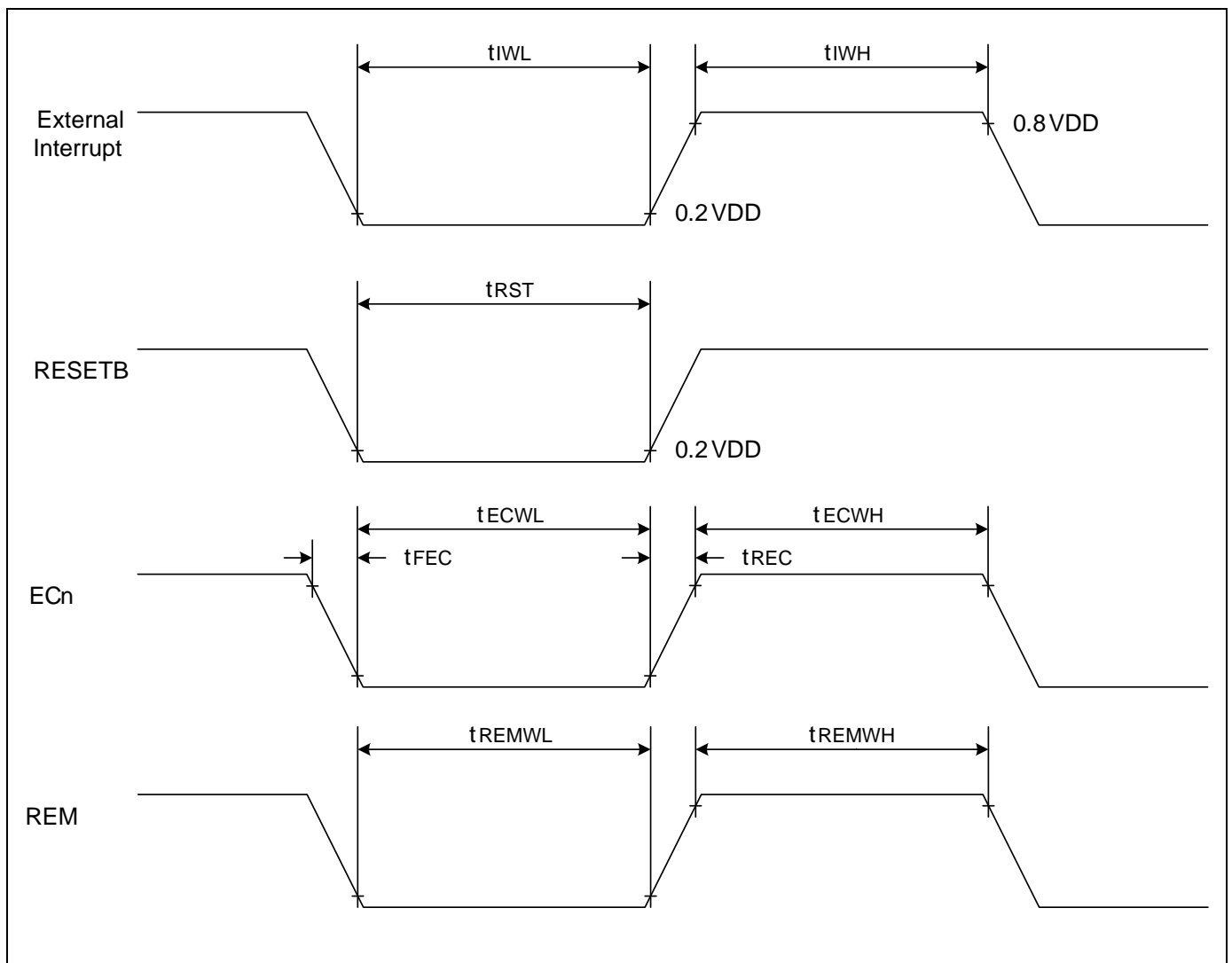

Figure 7.2 AC Timing

7.13 UART TIMING CHARACTERISTICS

($T_A = -40^{\circ}\text{C} \sim +85^{\circ}\text{C}$, $V_{DD} = 1.8\text{V} \sim 5.5\text{V}$, $f_{XIN} = 11.1\text{MHz}$)

| Parameter | Symbol | Min | Typ | Max | Units |
|--|---------------------|----------------|---------------------|------|-------|
| Serial port clock cycle time | t_{SCK} | 1250 | $t_{CPU} \times 16$ | 1650 | ns |
| Output data setup to clock rising edge | t_{s1} | 590 | $t_{CPU} \times 13$ | — | |
| Clock rising edge to input data valid | t_{s2} | — | — | 590 | |
| Output data hold after clock rising edge | t_{H1} | $t_{CPU} - 50$ | t_{CPU} | — | |
| Input data hold after clock rising edge | t_{H2} | 0 | — | — | |
| Serial port clock High, Low level width | t_{HIGH}, t_{LOW} | 470 | $t_{CPU} \times 8$ | 970 | |

Table 7.13 UART TIMING CHARACTERISTICS

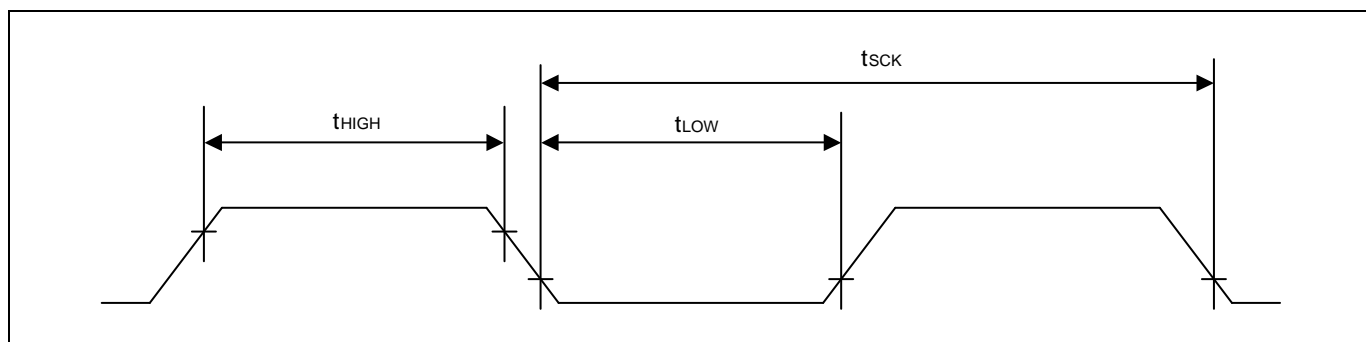

Figure 7.3 Waveform for UART Timing

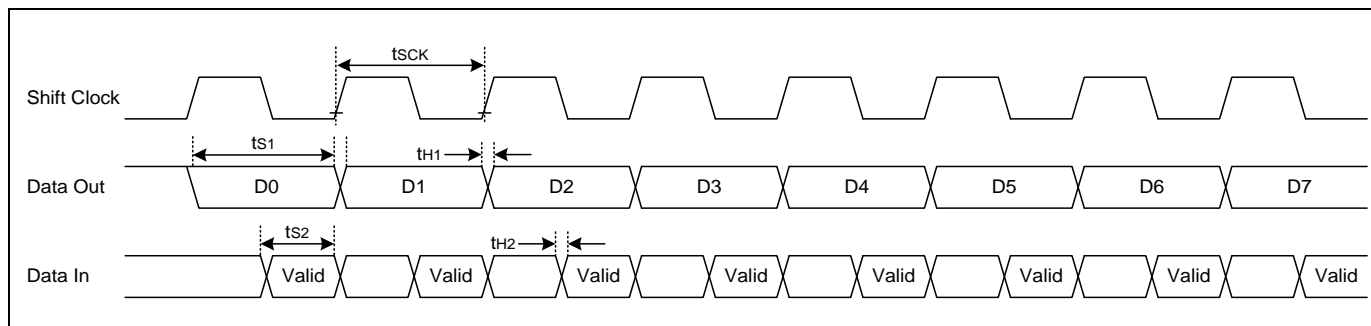

Figure 7.4 Timing Waveform for UART Module

7.14 Data Retention Voltage in Stop Mode

($T_A = -40^{\circ}\text{C} \sim +85^{\circ}\text{C}$, $V_{DD} = 1.8\text{V} \sim 5.5\text{V}$)

| Parameter | Symbol | Conditions | Min | Typ | Max | Units |
|-------------------------------|------------|---|-----|-----|-----|---------------|
| Data retention supply voltage | V_{DDDR} | — | 1.0 | — | 5.5 | V |
| Data retention supply current | I_{DDDR} | $V_{DDDR} = 1.8\text{V}$ ($T_A = 25^{\circ}\text{C}$), Stop mode | — | — | 1 | μA |

Table 7.14 Data Retention Voltage in Stop Mode

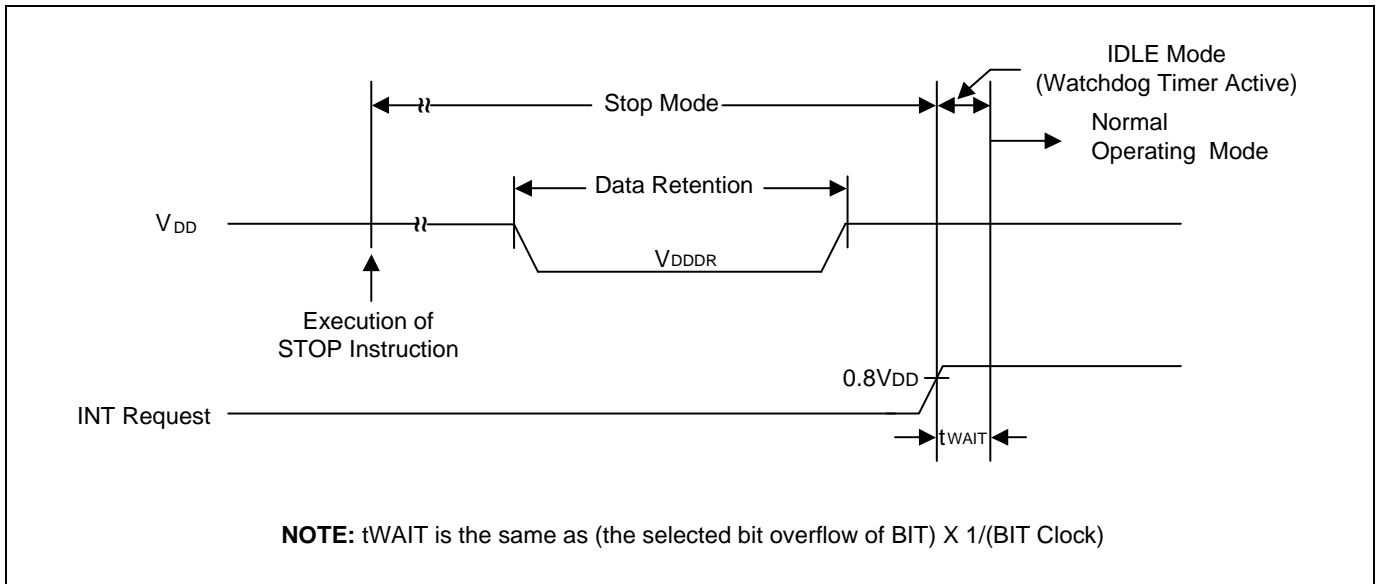

Figure 7.5 Stop Mode Release Timing when Initiated by an Interrupt

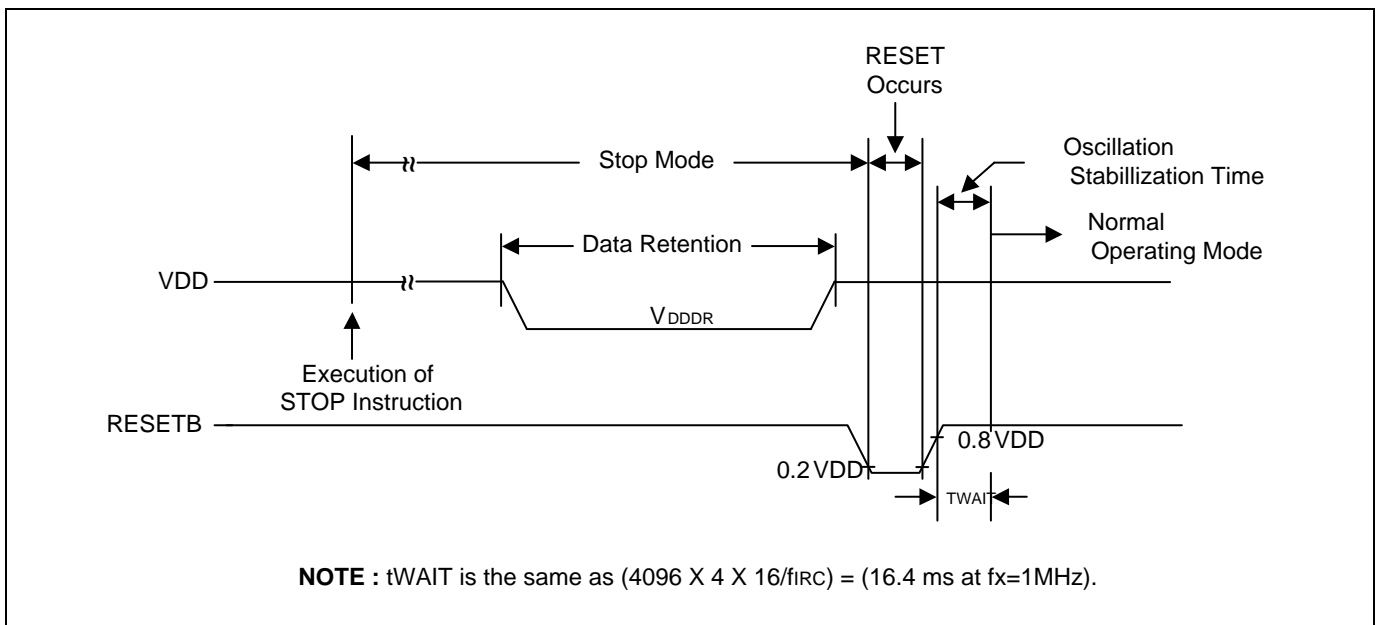

Figure 7.6 Stop Mode Release Timing when Initiated by RESETB

7.15 Internal Flash Rom Characteristics

(T_A=-40°C ~ +85°C, VDD=1.8V ~ 5.5V, VSS= 0V)

| Parameter | Symbol | Conditions | Min | Typ | Max | Units |
|-----------------------------|------------------|-------------------------------|-----|-----|---------|-------|
| Sector Write Time | t _{FSW} | – | – | 2.5 | 2.7 | ms |
| Sector Erase Time | t _{FSE} | – | – | 2.5 | 2.7 | |
| Hard-Lock Time | t _{FHL} | – | – | 2.5 | 2.7 | |
| Page Buffer Reset Time | t _{FBR} | – | – | – | 5 | us |
| Flash Programming Voltage | V _{PGM} | – | 2.0 | – | 5.5 | V |
| Flash Programming Frequency | f _{PGM} | – | 0.4 | – | – | MHz |
| Endurance of Write/Erase | N _{FWE} | Sector 0 to 763 | – | – | 10,000 | Times |
| | | Sector 764 to 767 (256 bytes) | – | – | 100,000 | |
| Flash Data Retention Time | t _{RT} | – | 10 | – | – | Years |

Table 7.15 Internal Flash Rom Characteristics

NOTE)

1. During a flash operation, SCLK[1:0] of SCCR must be set to “00” or “01” (HF INT-RC OSC or Main XTAL for system clock).

7.16 Input/Output Capacitance

(T_A=-40°C ~ +85°C, VDD=0V)

| Parameter | Symbol | Conditions | Min | Typ | Max | Units |
|--------------------|------------------|--|-----|-----|-----|-------|
| Input Capacitance | C _{IN} | f _x =1MHz Unmeasured pins are connected to Vss | – | – | 10 | pF |
| Output Capacitance | C _{OUT} | | | | | |
| I/O Capacitance | C _{IO} | | | | | |

Table 7.16 Input/Output Capacitance

7.17 Main Clock Oscillator Characteristics

($T_A = -40^{\circ}\text{C} \sim +85^{\circ}\text{C}$, $V_{DD} = 1.8\text{V} \sim 5.5\text{V}$)

| Oscillator | Parameter | Conditions | Min | Typ. | Max | Units |
|--------------------|----------------------------|---------------|-----|------|------|-------|
| Crystal | Main oscillation frequency | 2.0 V – 5.5 V | 0.4 | – | 4.2 | MHz |
| | | 2.4 V – 5.5 V | 0.4 | – | 8.0 | |
| | | 3.0 V – 5.5 V | 0.4 | – | 12.0 | |
| Ceramic Oscillator | Main oscillation frequency | 1.8 V – 5.5 V | 0.4 | – | 4.2 | |
| | | 2.4 V – 5.5 V | 0.4 | – | 8.0 | |
| | | 3.0 V – 5.5 V | 0.4 | – | 12.0 | |
| External Clock | XIN input frequency | 1.8 V – 5.5 V | 0.4 | – | 4.2 | MHz |
| | | 2.4 V – 5.5 V | 0.4 | – | 8.0 | |
| | | 3.0 V – 5.5 V | 0.4 | – | 12.0 | |

Table 7.17 Main Clock Oscillator Characteristics

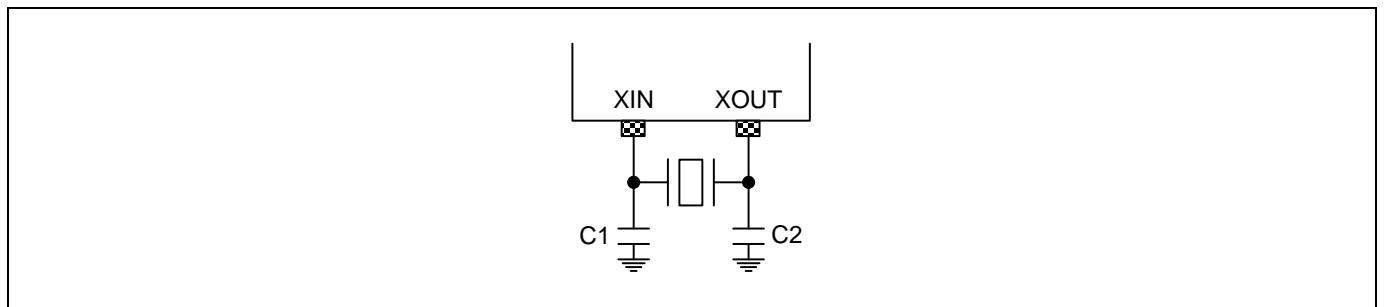

Figure 7.7 Crystal/Ceramic Oscillator

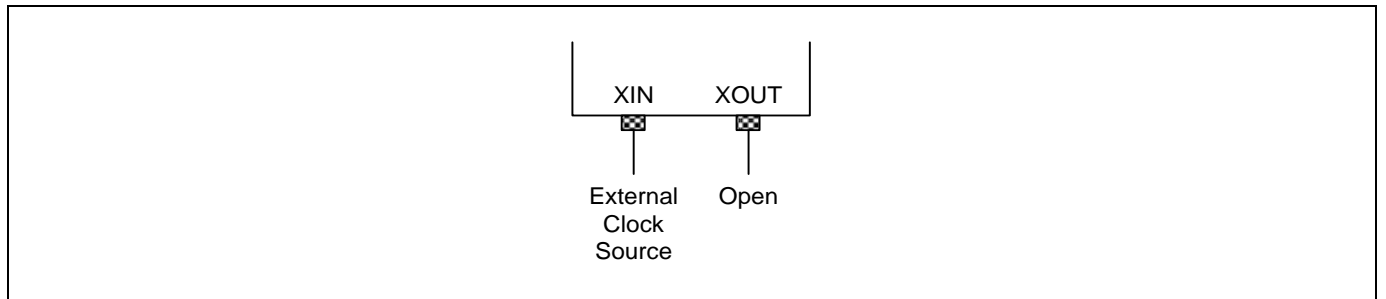

Figure 7.8 External Clock

7.18 Sub Clock Oscillator Characteristics

($T_A = -40^{\circ}\text{C} \sim +85^{\circ}\text{C}$, $V_{DD} = 1.8\text{V} \sim 5.5\text{V}$)

| Oscillator | Parameter | Conditions | Min | Typ. | Max | Units |
|----------------|---------------------------|---------------|-----|--------|-----|-------|
| Crystal | Sub oscillation frequency | 1.8 V – 5.5 V | 32 | 32.768 | 38 | kHz |
| External Clock | SXIN input frequency | | 32 | – | 100 | |

Table 7.18 Sub Clock Oscillator Characteristics

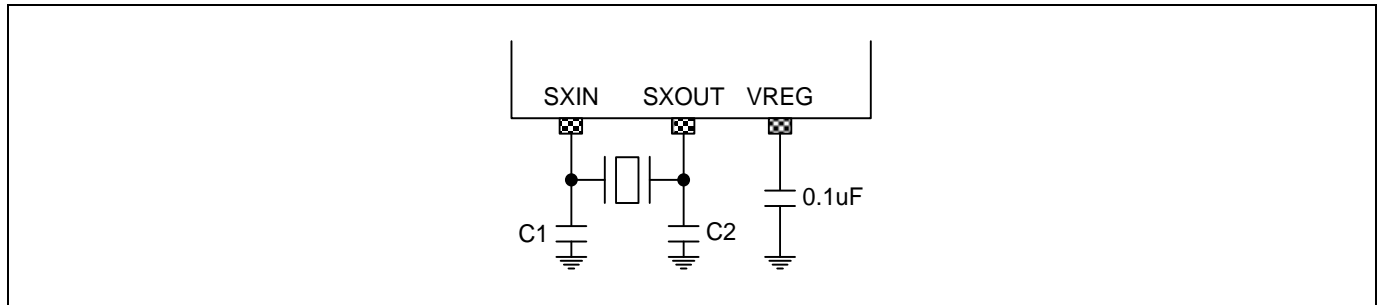

Figure 7.9 Crystal Oscillator

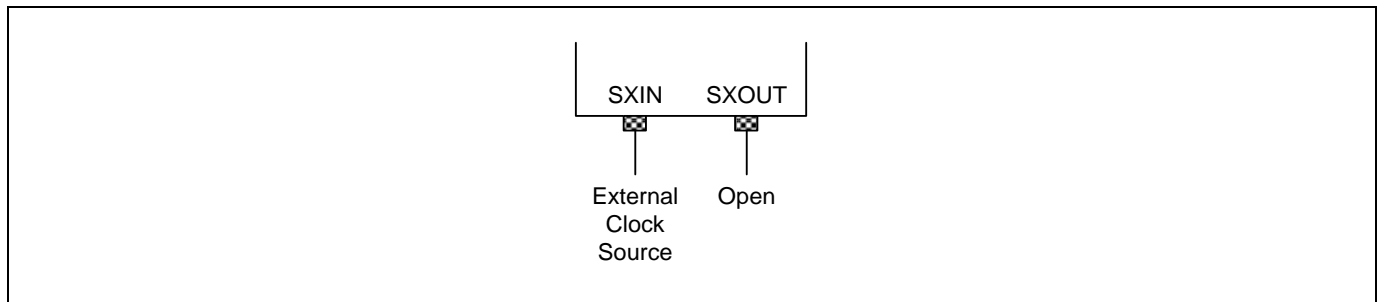

Figure 7.10 External Clock

7.19 Main Oscillation Stabilization Characteristics

($T_A = -40^\circ\text{C} \sim +85^\circ\text{C}$, $V_{DD} = 1.8\text{V} \sim 5.5\text{V}$)

| Oscillator | Conditions | Min | Typ. | Max | Units |
|----------------|---|-----|------|------|-------|
| Crystal | $f_{XIN} \geq 1\text{ MHz}$, $V_{DD} = 2.0\text{V} \sim 5.5\text{V}$ Oscillation stabilization occurs when V_{DD} is equal to the minimum oscillator voltage range. | - | - | 60 | ms |
| Ceramic | $f_{XIN} \geq 1\text{ MHz}$, $V_{DD} = 1.8\text{V} \sim 5.5\text{V}$ Oscillation stabilization occurs when V_{DD} is equal to the minimum oscillator voltage range. | - | - | 10 | |
| External Clock | $f_{XIN} = 0.4\text{ to }12\text{ MHz}$ XIN input high and low width (t_{XL} , t_{XH}) | 42 | - | 1250 | ns |

Table 7.19 Main Oscillation Stabilization Characteristics

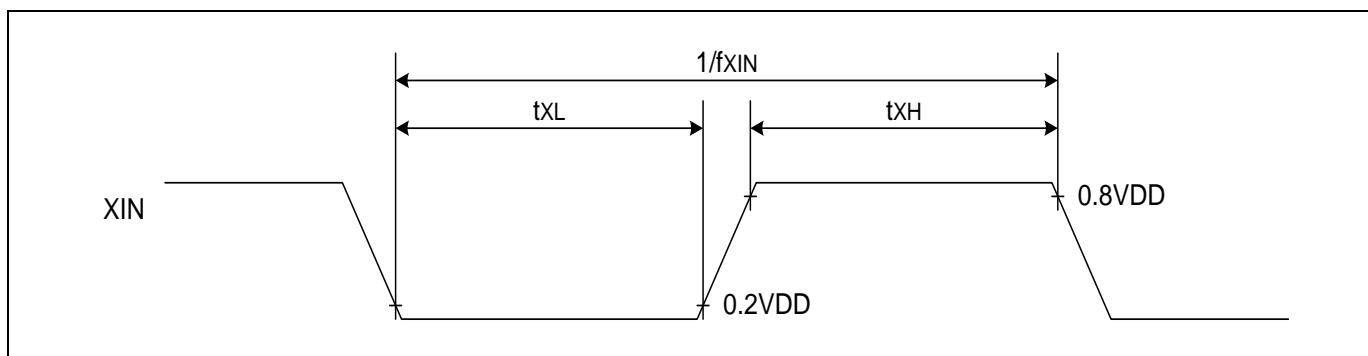

Figure 7.11 Clock Timing Measurement at XIN

7.20 Sub Oscillation Stabilization Characteristics

($T_A = -40^\circ\text{C} \sim +85^\circ\text{C}$, $V_{DD} = 1.8\text{V} \sim 5.5\text{V}$)

| Oscillator | Conditions | Min | Typ. | Max | Units |
|----------------|---|-----|------|-----|-------|
| Crystal | - | - | - | 10 | sec |
| | $V_{DD} = 3.0\text{V}$, $T_A = 25^\circ\text{C}$ | - | 0.7 | 1.5 | |
| External Clock | SXIN input high and low width (t_{XL} , t_{XH}) | 5 | - | 15 | us |

Table 7.20 Sub Oscillation Stabilization Characteristics

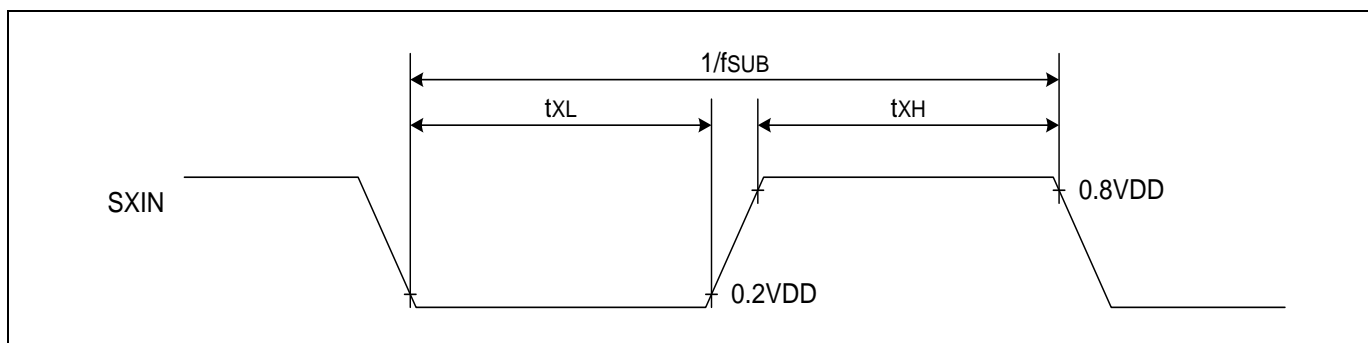

Figure 7.12 Clock Timing Measurement at SXIN

7.21 Operating Voltage Range

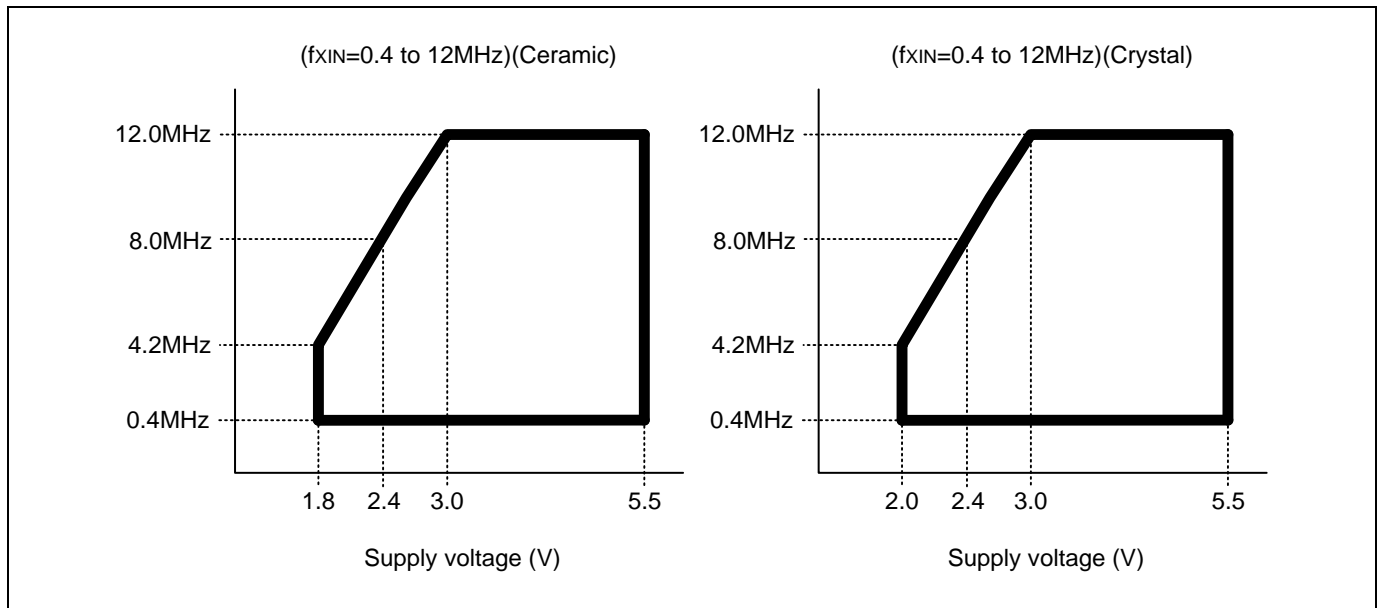

Figure 7.13 Operating Voltage Range (Main OSC)

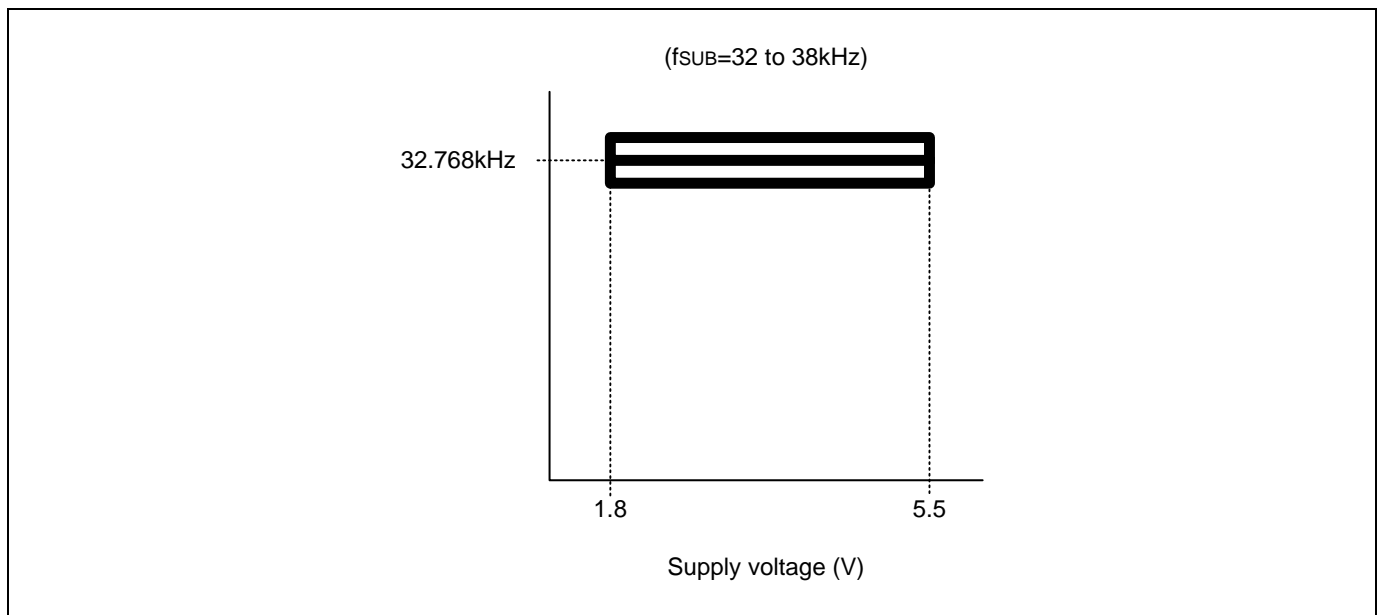

Figure 7.14 Operating Voltage Range (Sub OSC)

7.22 Recommended Circuit and Layout

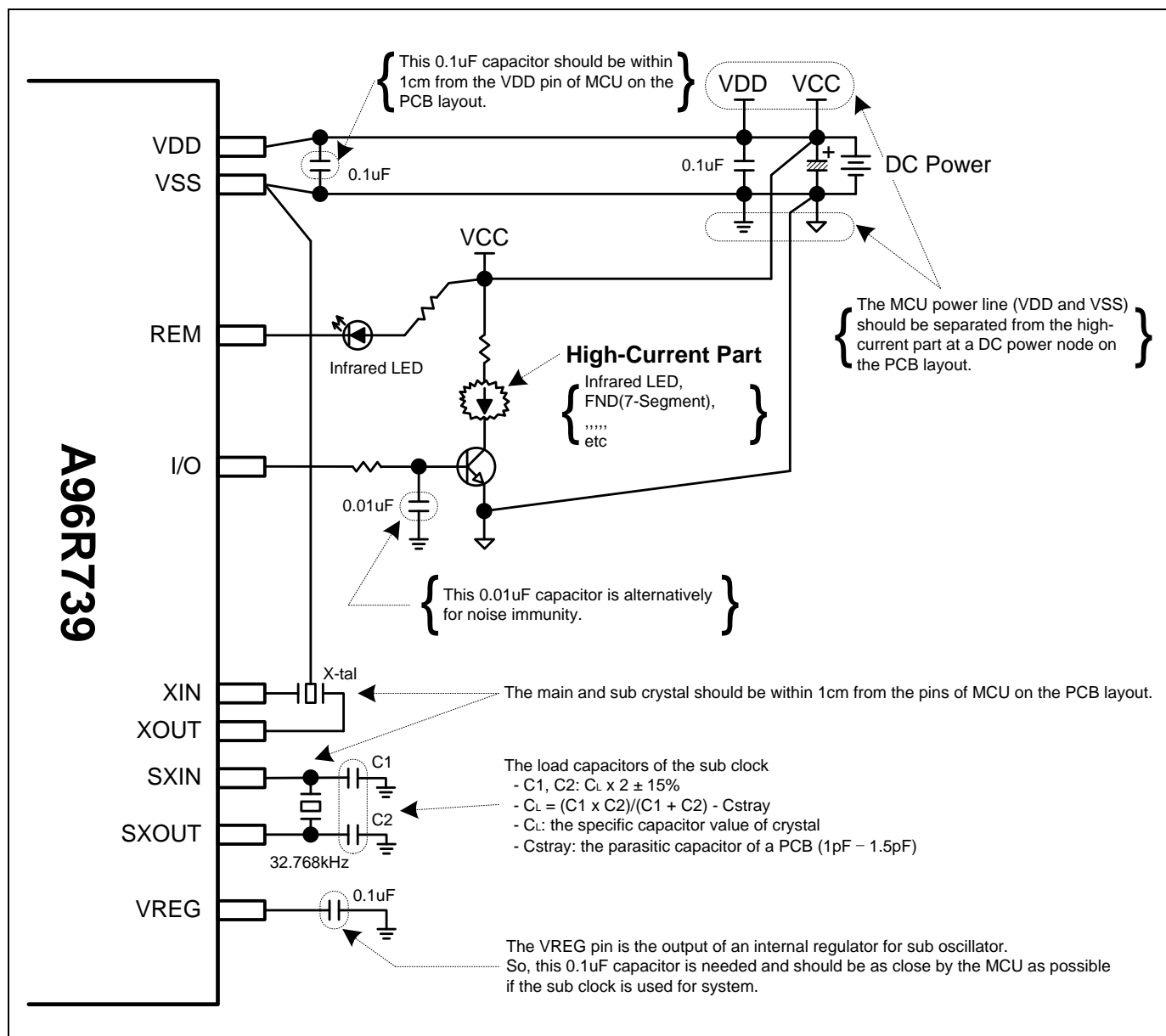

Figure 7.15 Recommended Circuit and Layout

7.23 Recommended Circuit for Remote controller

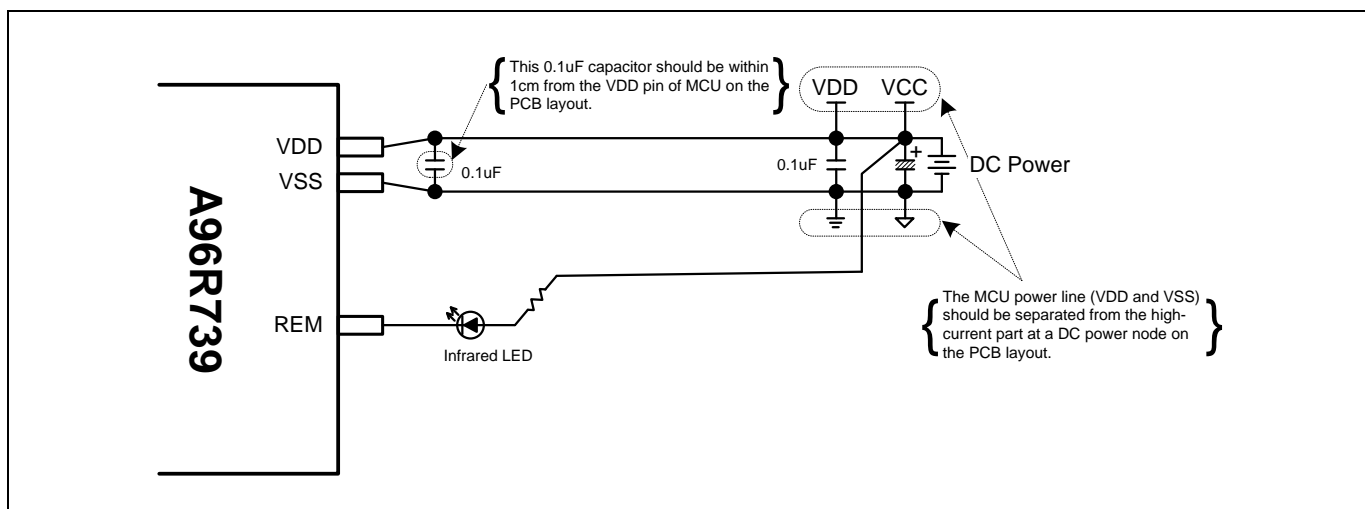

Figure 7.16 Recommended Circuit for Remote controller

7.24 Recommended Circuit and Layout with SMPS Power

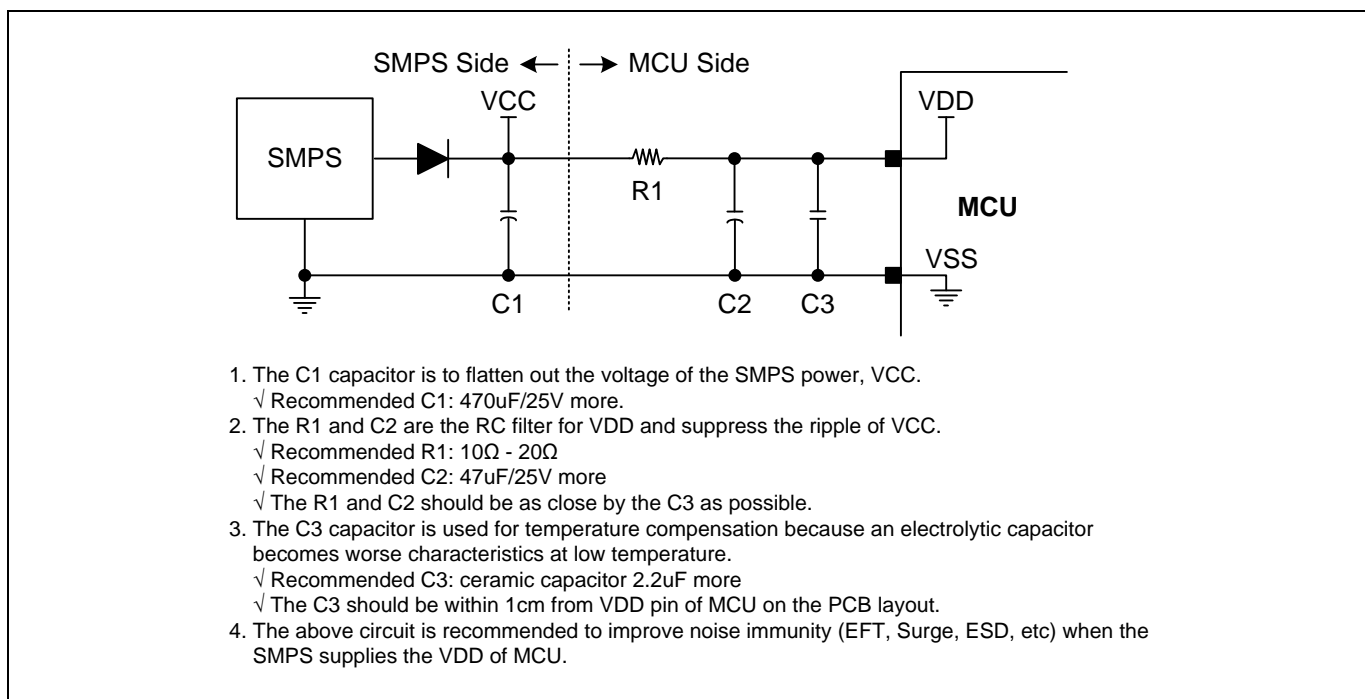

Figure 7.17 Recommended Circuit and Layout with SMPS Power

7.25 Typical Characteristics

These graphs and tables provided in this section are only for design guidance and are not tested or guaranteed. In graphs or tables some data are out of specified operating range (e.g. out of specified VDD range). This is only for information and devices are guaranteed to operate properly only within the specified range.

The data presented in this section is a statistical summary of data collected on units from different lots over a period of time. "Typical" represents the mean of the distribution while "max" or "min" represents (mean + 3σ) and (mean - 3σ) respectively where σ is standard deviation.

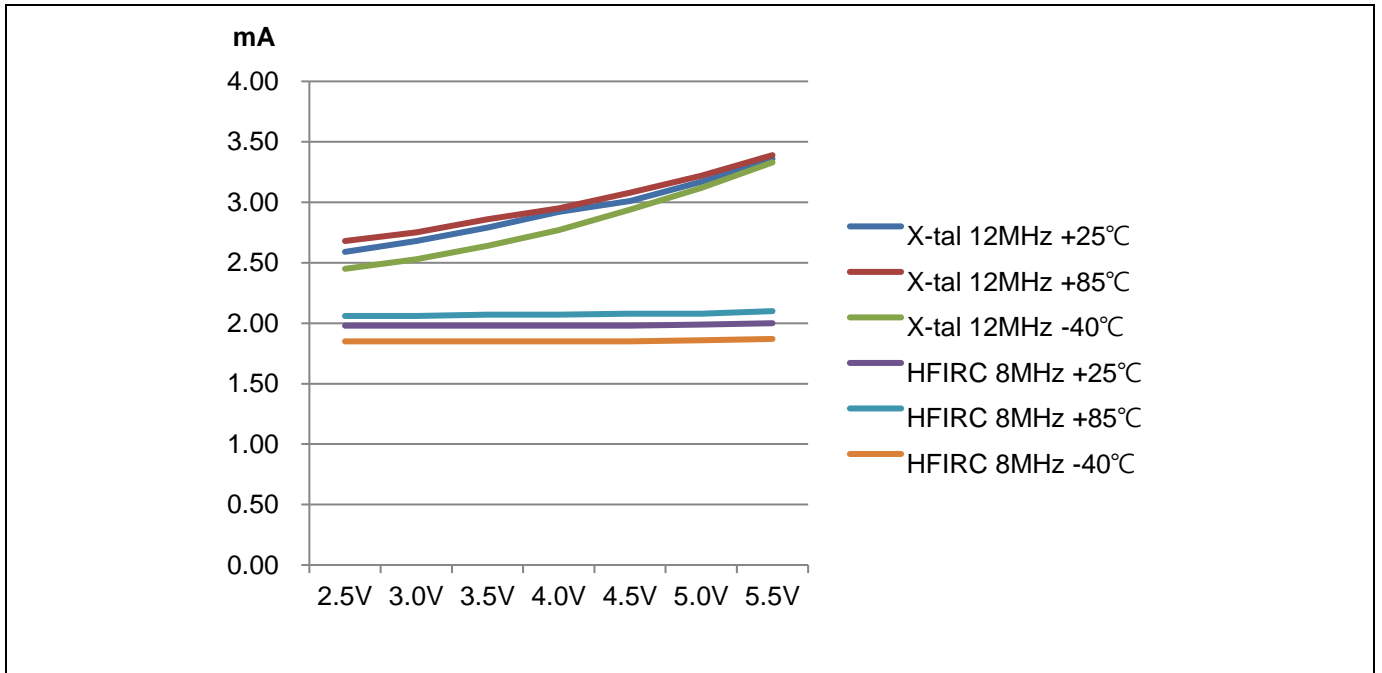

Figure 7.18 RUN (IDD1) Current

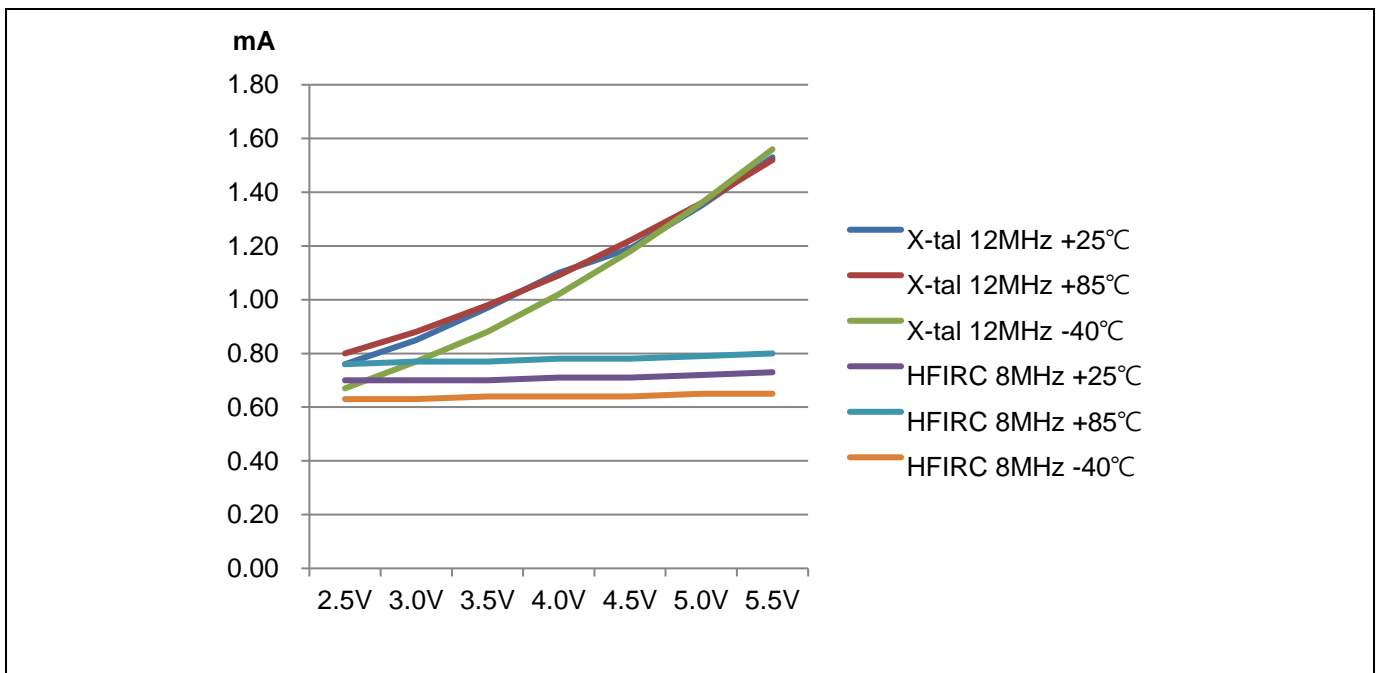

Figure 7.19 IDLE (IDD2) Current

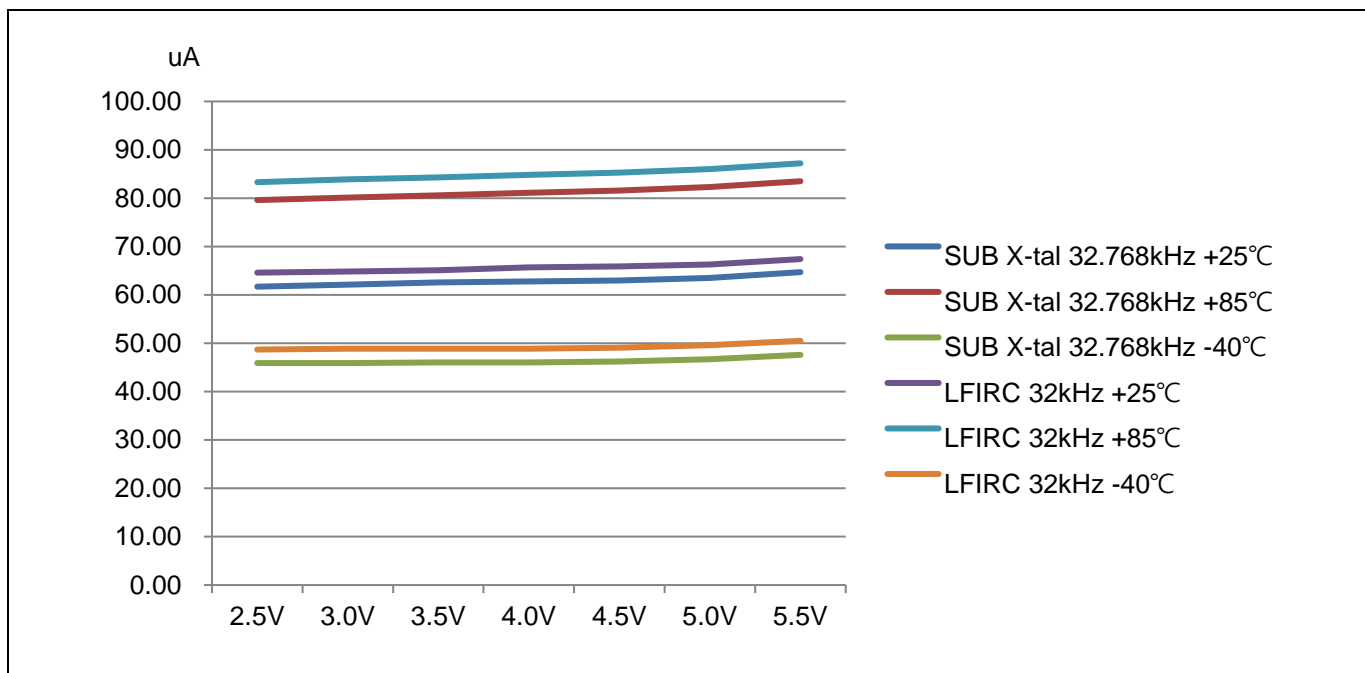

Figure 7.20 RUN (IDD3) Current

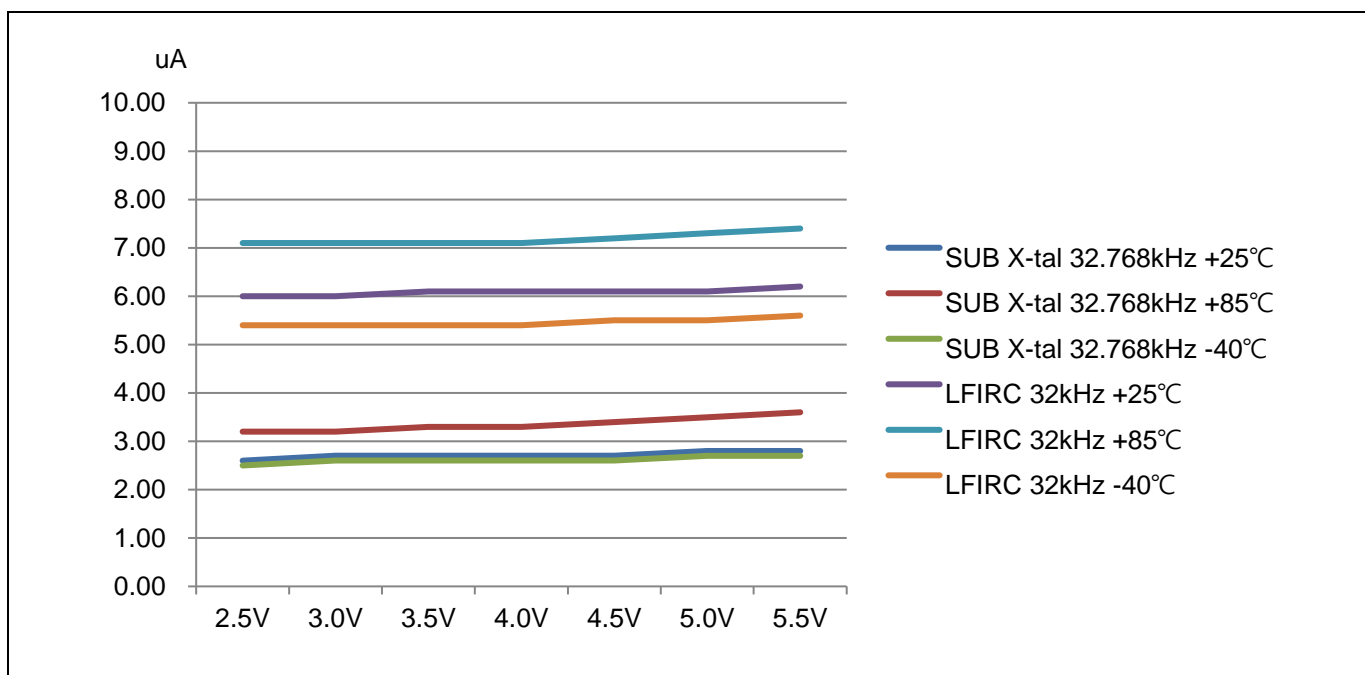

Figure 7.21 IDLE (IDD4) Current

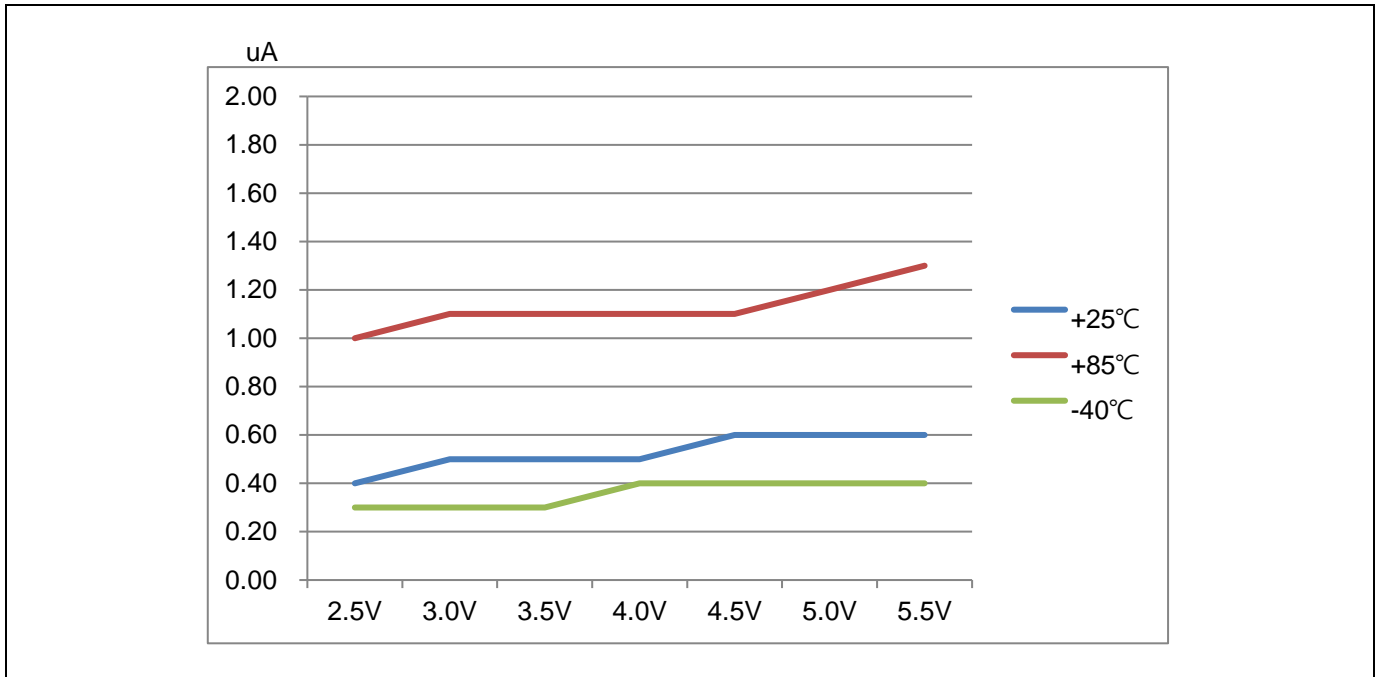

Figure 7.22 STOP (IDD5) Current

Table of contents

| | |
|---|-----------|
| Revision history | 2 |
| 1 Overview | 3 |
| 1.1 Description | 3 |
| 1.2 Features..... | 4 |
| 1.3 Development tools | 5 |
| 1.3.1 Compiler | 5 |
| 1.3.2 OCD(On-chip debugger) emulator and debugger | 5 |
| 1.3.3 Programmer..... | 6 |
| 1.4 MTP programming | 8 |
| 1.4.1 Overview..... | 8 |
| 1.4.2 On-Board programming..... | 8 |
| 1.4.3 Circuit Design Guide..... | 9 |
| 2 Block diagram | 10 |
| 3 Pin assignment | 11 |
| 4 Package Diagram | 15 |
| 5 Pin Description..... | 19 |
| 6 Port Structures | 23 |
| 6.1 General Purpose I/O Port | 23 |
| 6.2 External Interrupt I/O Port..... | 24 |
| 7 Electrical Characteristics | 25 |
| 7.1 Absolute Maximum Ratings | 25 |
| 7.2 Recommended Operating Conditions | 25 |
| 7.3 A/D Converter Characteristics | 26 |
| 7.4 Power-On Reset Characteristics | 27 |
| 7.5 Low Voltage Reset and Low Voltage Indicator Characteristics | 28 |
| 7.6 Low Current Low Voltage Reset Characteristics | 28 |
| 7.7 High Frequency Internal RC Oscillator Characteristics | 29 |
| 7.8 Low Frequency Internal RC Oscillator Characteristics | 29 |
| 7.9 Internal Watch-Dog Timer RC Oscillator Characteristics..... | 29 |
| 7.10 LCD Voltage Characteristics..... | 30 |
| 7.11 DC Characteristics | 31 |
| 7.11 DC Characteristics (Continued) | 32 |
| 7.12 AC Characteristics | 33 |
| 7.13 UART TIMING CHARACTERISTICS | 34 |
| 7.14 Data Retention Voltage in Stop Mode | 35 |
| 7.15 Internal Flash Rom Characteristics | 36 |
| 7.16 Input/Output Capacitance | 36 |
| 7.17 Main Clock Oscillator Characteristics | 37 |
| 7.18 Sub Clock Oscillator Characteristics | 38 |
| 7.19 Main Oscillation Stabilization Characteristics | 39 |
| 7.20 Sub Oscillation Stabilization Characteristics | 39 |
| 7.21 Operating Voltage Range | 40 |
| 7.22 Recommended Circuit and Layout | 41 |
| 7.23 Recommended Circuit for Remote controller | 42 |
| 7.24 Recommended Circuit and Layout with SMPS Power | 42 |
| 7.25 Typical Characteristics..... | 43 |
| Table of contents..... | 46 |