

Rx Tx Line Interface for Smoke Detector Controller LDO, UVLO function, Tx/Rx functions

Datasheet Version 1.22

Features

- High voltage input/ low voltage output
- Built-in analog functions
 - Low Drop Output (LDO) voltage 3.0V $\pm 3.0\%$ (@24V, -10°C~60°C)
 - Comparator for line interface Rx
 - TR for line interface Tx
 - UVLO
- VIN input voltage range
 - Power supply 8.5V to 42V
 - Signal input 0.0V to 42V
- Operating temperature: - 40°C to 85°C ambient temperature
- 8 SOP package

It protects power devices by preventing damage from short to ground or short to battery. In a case that the power is supplied through a long cable from a main board, the power device requires protection for itself. Many power devices are designed to operate with low supply voltage, but they require a certain level of viable voltage to operate correctly.

AL1113/AL1115 incorporates LDO (Low Dropout voltage regulator). It maintains its specified output voltage over a wide range of load current and input voltage, to control accurate power supply.

Application

- Smoke detector
- Line interface
- Battery-powered equipment

In addition, AL1113/AL1115 uses UVLO (Under Voltage Lockout) function that ensures voltage to be supplied only when the system input voltage is above the specified threshold. The UVLO is an important function because it only allows the device to power on when the input voltage is at or above the level the device requires for stable operation.

Introduction

AL1113/AL1115 is an Integrated Circuit (IC).

Product selection table

Table 1. Device Summary

Device name	Supply Voltage	LDO Output Voltage	Static Current	Package	Remark
AL1113HDN	8.5V~42V	3V +3% @-10°C~60°C	MAX. 90uA @Vout =24V, 25°C	8 SOP	Separated VOUT_R, VINTx
AL1115HDN					Common VOUT_R,= VOUT VINTx =VIN

Contents

Features	1
Application.....	1
Introduction.....	1
Product selection table.....	1
1 Description	5
1.1 Device overview	5
1.2 Block diagram.....	6
2 Product overview.....	8
2.1 Initial function	8
2.2 Power charging	8
2.3 Rx and Tx functions.....	9
2.4 LDO (Low Dropout Voltage) regulator.....	10
2.5 UVLO (Under Voltage Lockout) function.....	10
3 Pinouts and pin descriptions	11
3.1 Pinouts	11
3.2 Pin description.....	12
4 Port structure and application circuits	13
4.1 Port structure.....	13
4.2 Application circuits.....	14
4.2.1 Application circuit for case 1, 2 and 3.....	14
5 Electrical characteristics.....	16
5.1 Absolute maximum ratings.....	16
5.2 Recommended operating conditions	16
5.3 POR characteristics.....	17
5.4 DC electrical characteristics	18
5.5 AC electrical characteristics	19
6 Package information	20
6.1 8 SOP package	20
7 Ordering information	22
Revision history.....	23

List of figures

Figure 1. AL1113 Block Diagram.....	6
Figure 2. AL1115 Block Diagram.....	7
Figure 3. Reset Signal Generation at VDD 2.4V.....	8
Figure 4. Inrush Current Limit by Power Charging	8
Figure 5. RXT and TXR Timing Diagram	9
Figure 6. LDO Regulator in Block Diagram.....	10
Figure 7. 8SOP Pinouts (AL1113)	11
Figure 8. 8SOP Pinouts (AL1115)	11
Figure 9. Port Structure of VOUT, VOUT_R, and VIN	13
Figure 10. Port Structure of RXT	13
Figure 11. Port Structure of TXR.....	13
Figure 12. Application Circuit of Case 1	14
Figure 13. Application Circuit of Case 2.....	14
Figure 14. Application Circuit of Case 3.....	15
Figure 15. POR Timing Diagram.....	17
Figure 16. VIN and RXT Timing Diagram	19
Figure 17. AC Timing Diagram	19
Figure 18. 8 SOP Package Outline	20
Figure 19. AL1113/AL1115 Series Numbering Nomenclature	22

List of tables

Table 1. Device Summary	1
Table 2. Features and Functions of AL1113/ AL1115	5
Table 3. Normal Pin Description.....	12
Table 4. Application Circuit for Case 1, 2 and 3	15
Table 5. Absolute Maximum Ratings	16
Table 6. Recommended Operating Conditions	16
Table 7. POR Characteristics	17
Table 8. DC Electrical Characteristics	18
Table 9. AC Electrical Characteristics	19
Table 10. 8SOP Package Mechanical Data	21
Table 11. AL1113/ AL1115 Ordering Information	22

1 Description

AL1113/AL1115 is a line interface IC for a fire system controller such as a smoke detector and a fire detector. It is a set of an LDO, a UVLO function, and Tx/ Rx interface functions.

AL1113/AL1115 runs with high voltage input and 3V of voltage output (LDO). An LDO supplies stable power to a target MCU, and enables the connection of multiple units in a fire fighting system.

There are Tx and Rx pins for 1-line communication.

1.1 Device overview

Table 2 introduces features and functions of AL1113/AL1115.

Table 2. Features and Functions of AL1113/ AL1115

Function	AL1113/AL1115
VIN voltage range	<ul style="list-style-type: none"> Power supply 8.5V to 42V Signal input 0.0V to 42V
Low power consumption	Max. 90uA (@VOUT=24V, room temperature)
Low Dropout (LDO) voltage	3V \pm 3% (@24V, -10°C to 60°C)
LDO drive ability	20mA (@VOUT = 24V)
Under Voltage Lockout (UVLO)	Internal UVLO function
Line interface	<ul style="list-style-type: none"> Comparator for line interface Rx TR for line interface Tx
ESD performance	<ul style="list-style-type: none"> 2000V human body model 200V machine model
RF-EMS(IEC 61000-4-3)	<ul style="list-style-type: none"> LV3(10V/m)
Package type	8 SOP

1.2 Block diagram

Figure 1 and Figure 2 shown below introduce AL1113 and AL1115 in block diagrams.

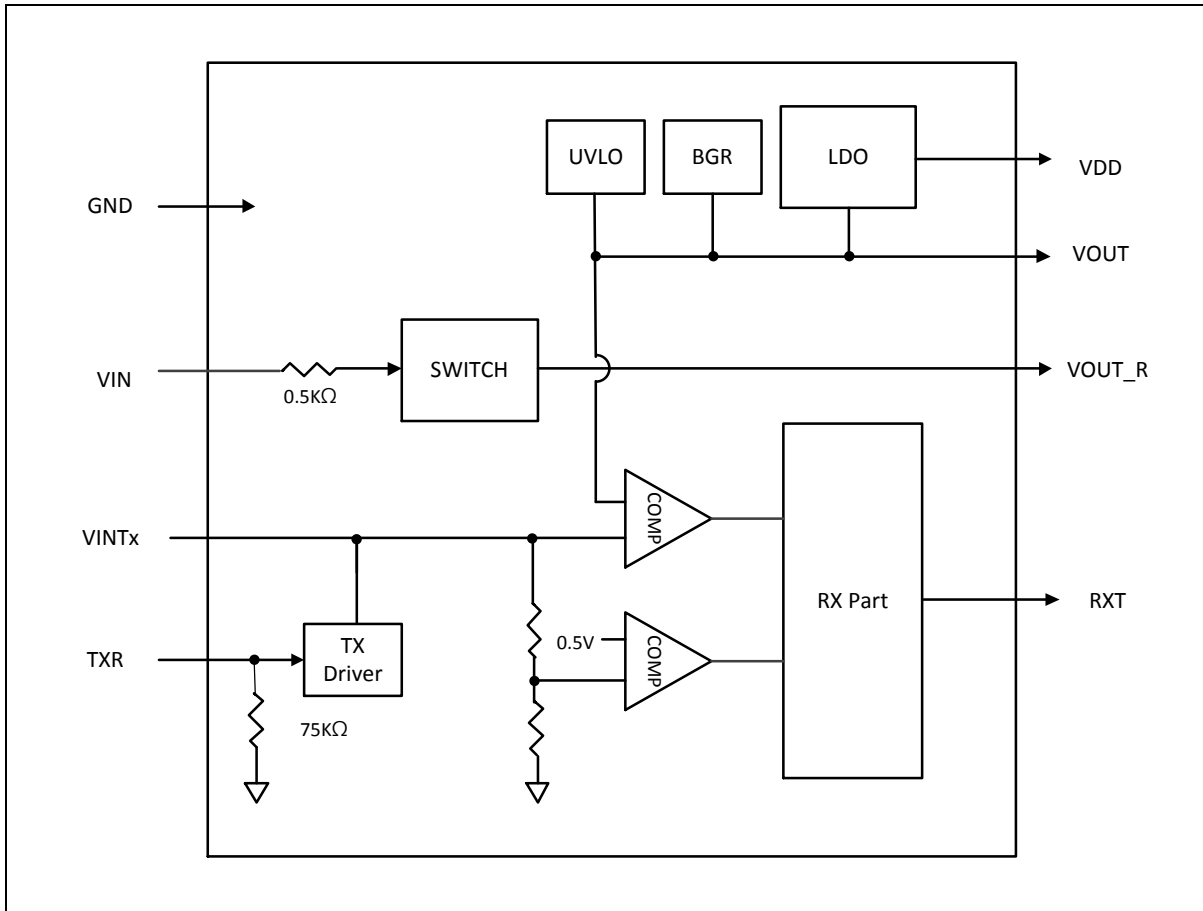

Figure 1. AL1113 Block Diagram

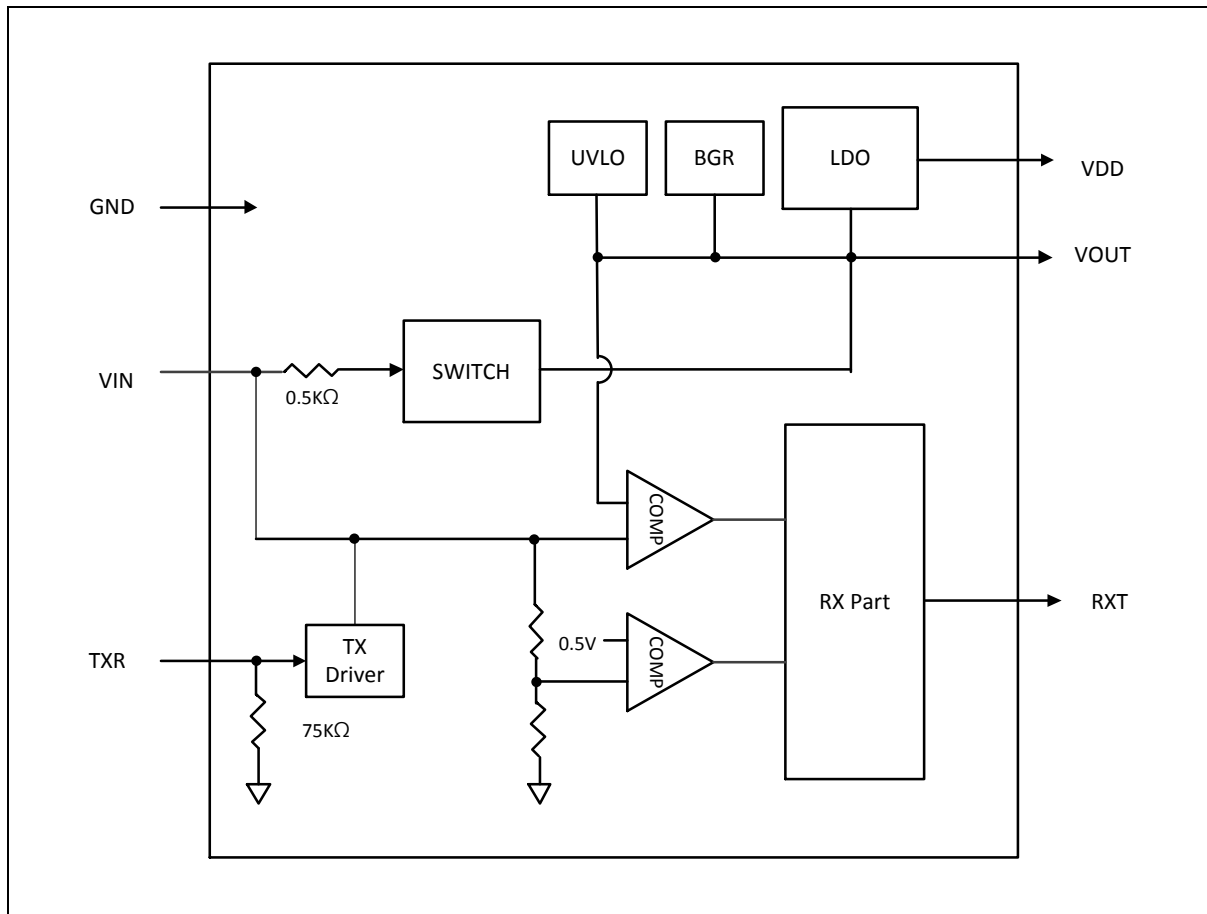

Figure 2. AL1115 Block Diagram

2 Product overview

The following sections intend to give an overview of the basic features of the AL1113/AL1115. For more detailed information, please refer to the corresponding User's Manual.

2.1 Initial function

VDD increases as the external power VIN increases. When the VDD reaches to 2.4V, a UVLO signal turns to high and releases an internal reset signal.

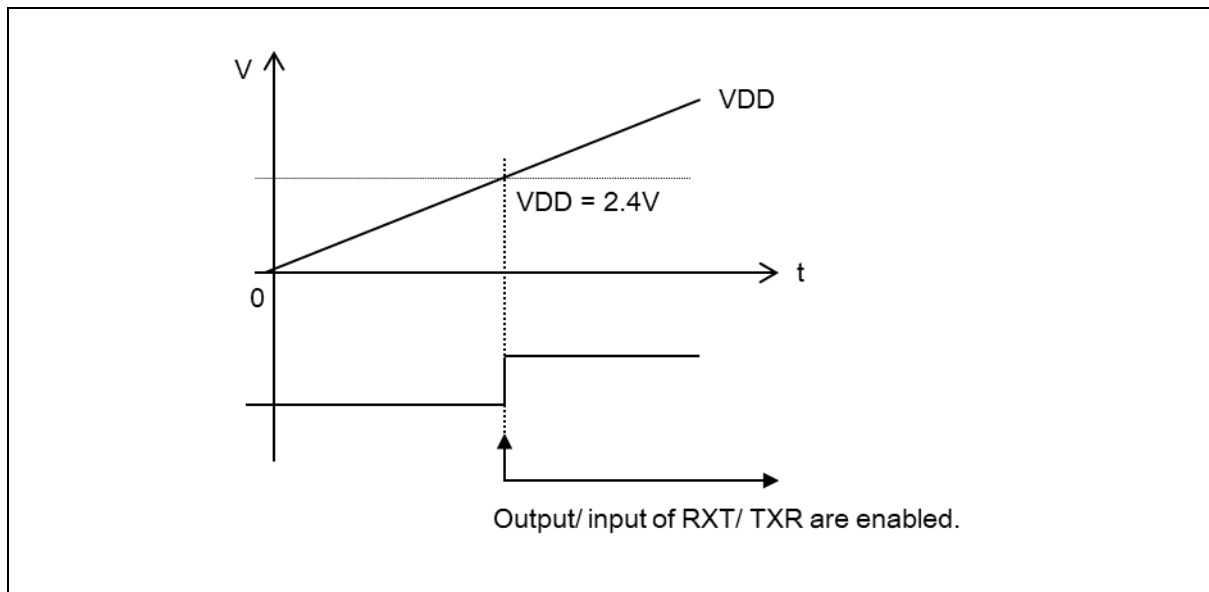

Figure 3. Reset Signal Generation at VDD 2.4V

2.2 Power charging

AL1113/AL1115 limits inrush current using a PMOS transistor. As shown in Figure 4, when a voltage level of VIN is higher than VOUT, a switch turns on through a comparator. At this moment, a capacitor C0 of VOUT is charged. If a voltage level of VOUT is higher than or equal to VIN, a switch turns off.

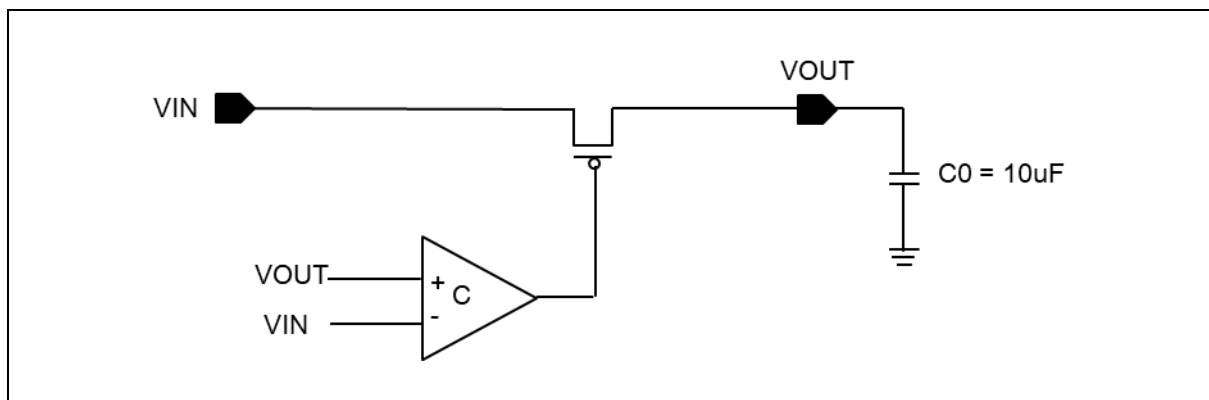

Figure 4. Inrush Current Limit by Power Charging

2.3 Rx and Tx functions

AL1113/AL1115 supports Rx and Tx functions along with an external comparator and resistor components. While AL1113/AL1115 is used for the interface communication, data can be transferred by changing VIN voltage.

When the voltage difference between VOUT and VIN is bigger than 7.5V, state of RXT pin changes to high and communication with a target MCU is performed through the RXT pin

If VOUT is higher than operating voltage (8.5V or higher) and VIN is lower than 7.5V, state of RXT pin becomes high. This is called 'Tx period' and a TXR pin is used to change VIN voltage at a target MCU.

Figure 5 shows timing diagram of a comparator which is incorporated in AL1113/AL1115.

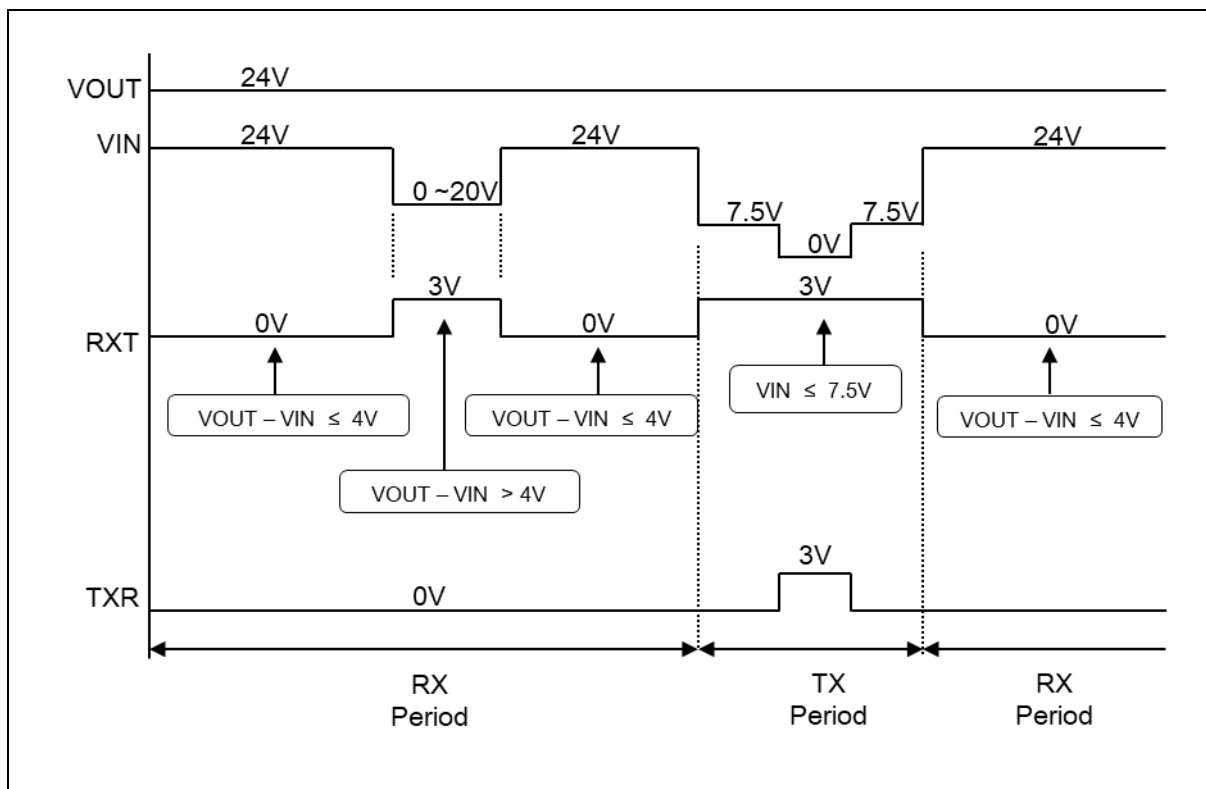

Figure 5. RXT and TXR Timing Diagram

2.4 LDO (Low Dropout Voltage) regulator

AL1113/AL1115 includes an LDO (Low Dropout Voltage) regulator for microcontroller and an indicated LED driver power.

As shown in Figure 6, during initial operations when power or signal line is connected to VIN pin, C0 capacitor of pin VOUT is charged. BGR circuit generates VREF voltage, and LDO generates LDO voltage by referencing VREF.

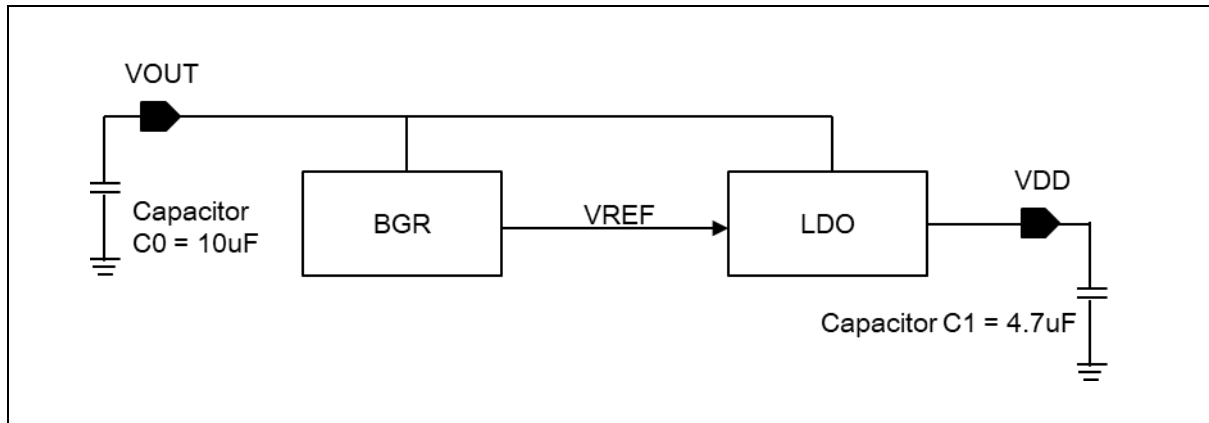

Figure 6. LDO Regulator in Block Diagram

2.5 UVLO (Under Voltage Lockout) function

AL1113/AL1115 features UVLO function that is used to turn off the input power in the event of the voltage dropping below the operational value.

3 Pinouts and pin descriptions

In this section, AL1113/AL1115 pinouts and pin descriptions are introduced.

3.1 Pinouts

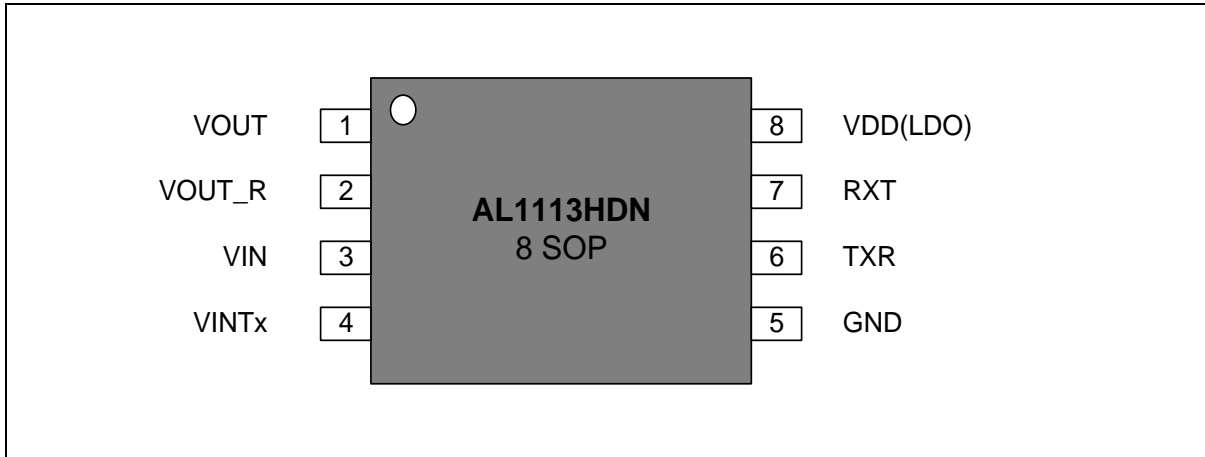

Figure 7. 8SOP Pinouts (AL1113)

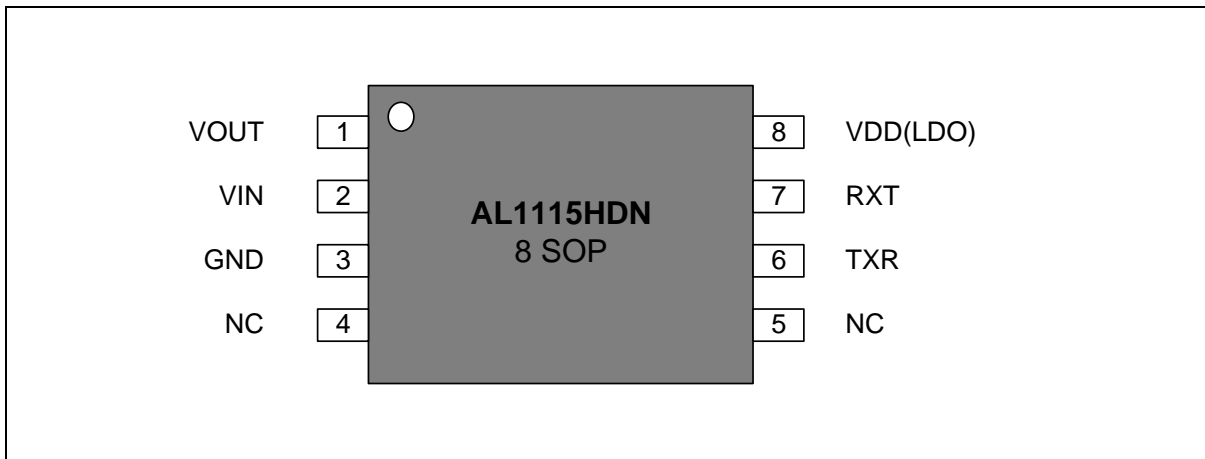

Figure 8. 8SOP Pinouts (AL1115)

3.2 Pin description

Table 3. Normal Pin Description

Pin name	I/O	Function	@ Reset	Shared with
VOUT	O	<ul style="list-style-type: none"> Internal power pin. It connects to a capacitor. 	Same I/O	—
VOUT_R	O	Switch output pin		—
VIN	I/O	Bridge output pin		—
VINTx	O	Transmission pin		—
GND	Ground	Ground pin		—
NC	—	No connection		—
NC	—	No connection		—
TXR	I	Input pin or signal transmission		—
RXT	O	Received signal output pin		—
VDD	O	LDO output pin		—

4 Port structure and application circuits

In this chapter, port structure of each port and application circuits are introduced.

4.1 Port structure

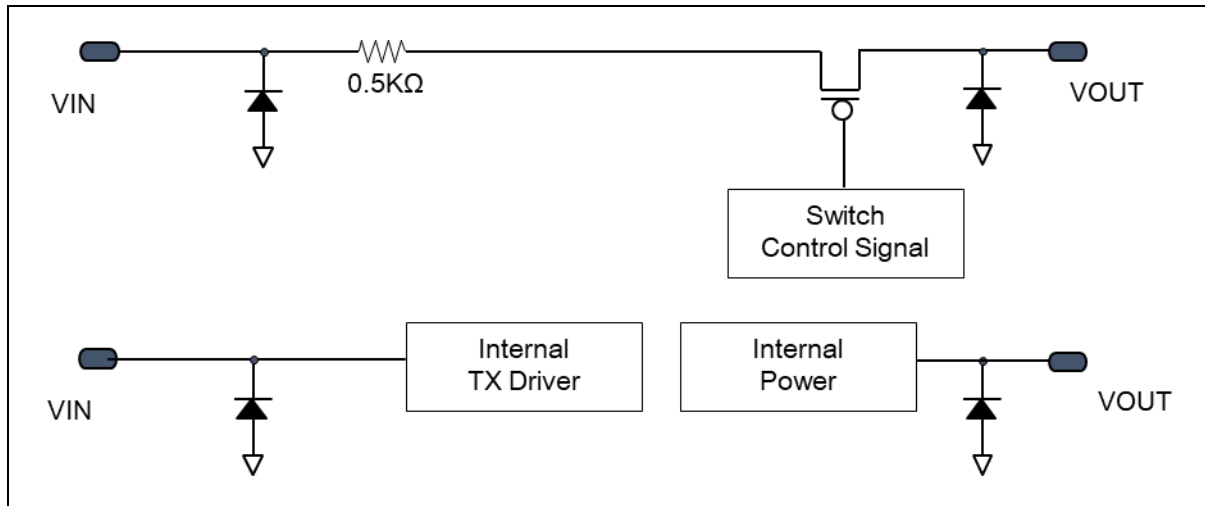

Figure 9. Port Structure of VOUT, VOUT_R, and VIN

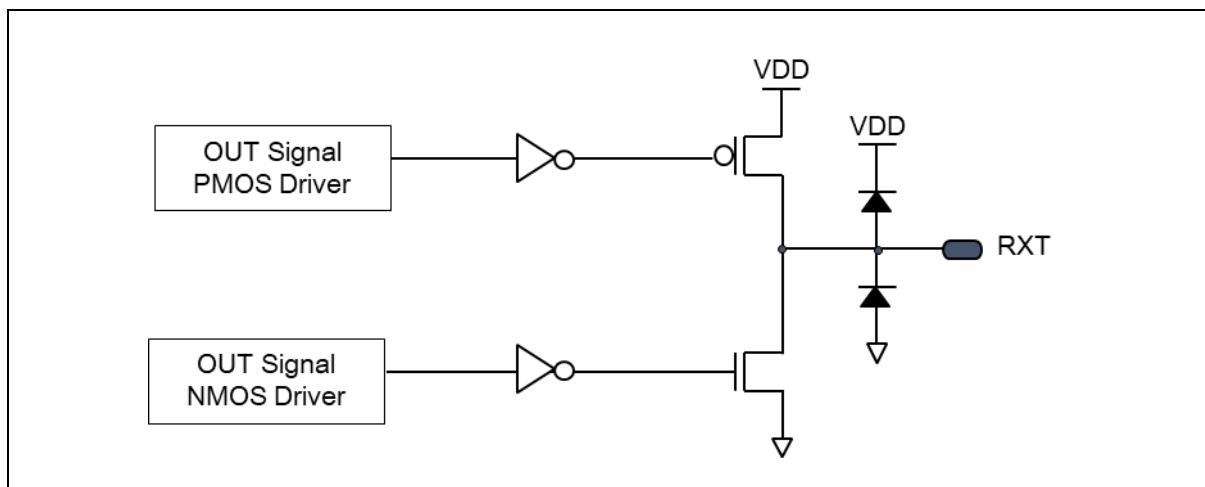

Figure 10. Port Structure of RXT

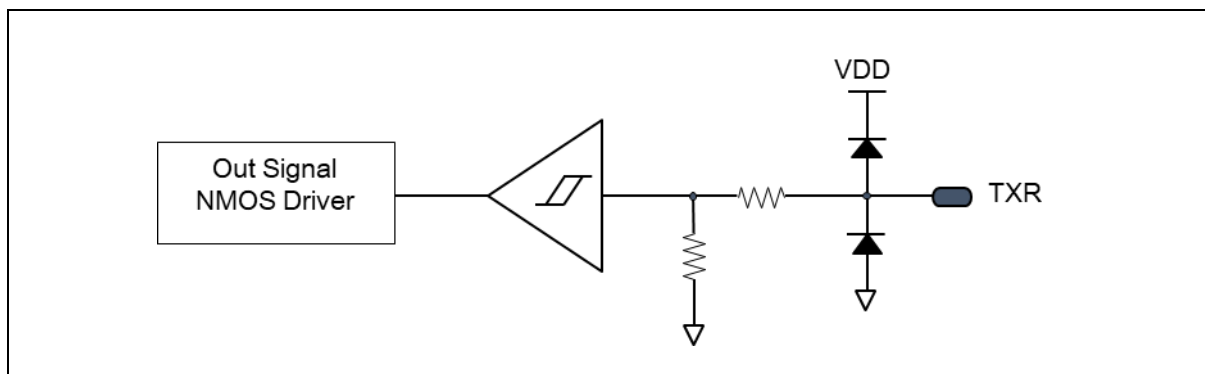

Figure 11. Port Structure of TXR

4.2 Application circuits

4.2.1 Application circuit for case 1, 2 and 3

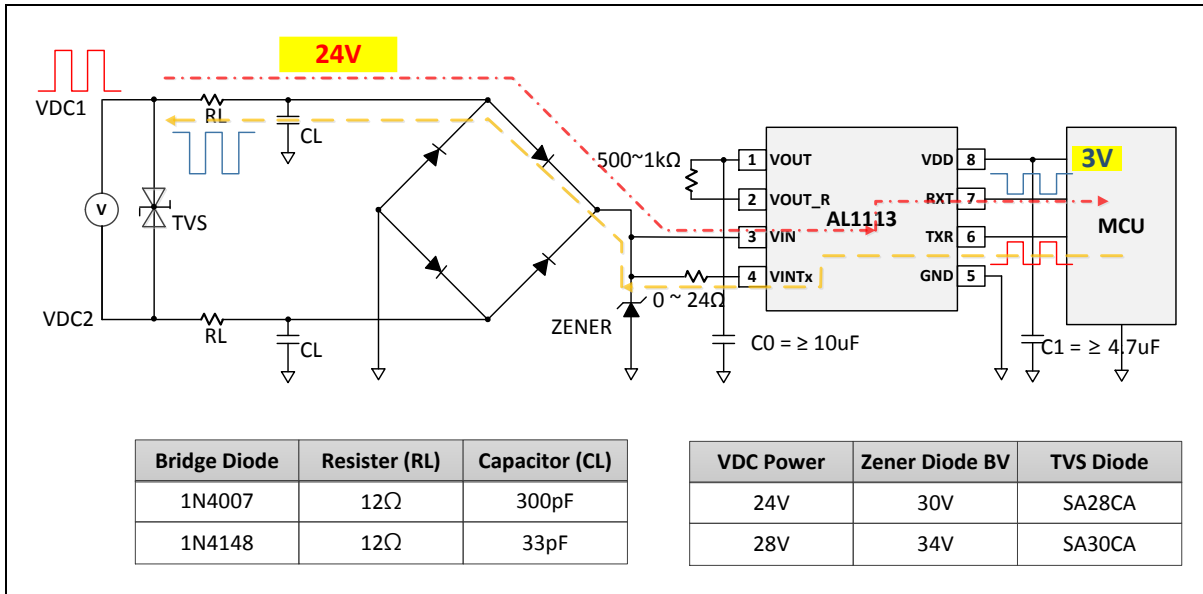

Figure 12. Application Circuit of Case 1

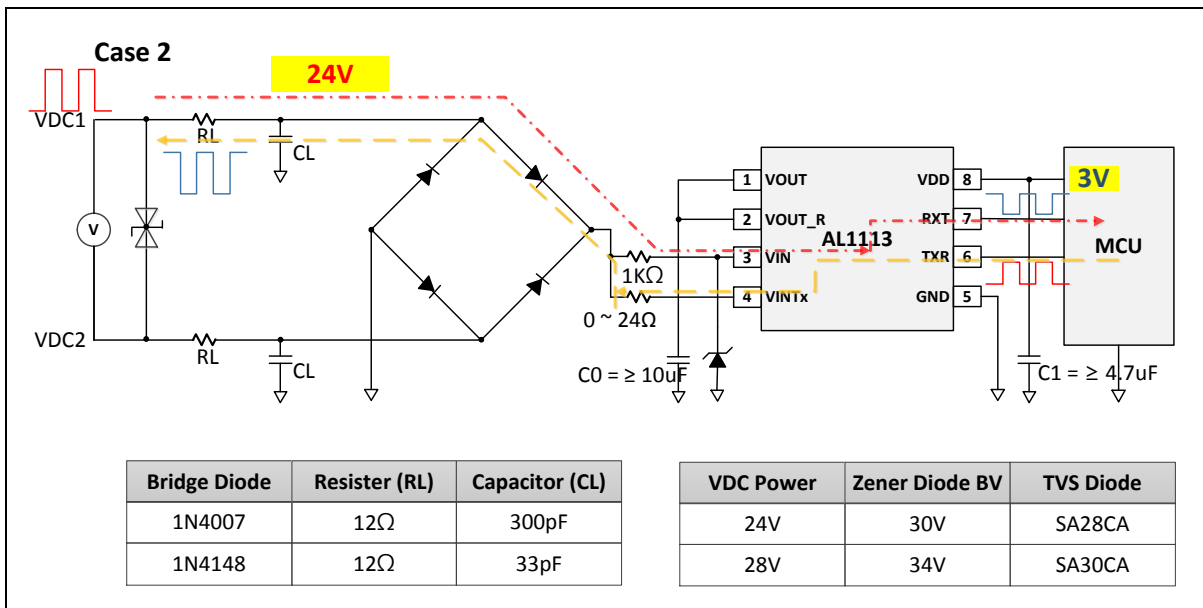

Figure 13. Application Circuit of Case 2

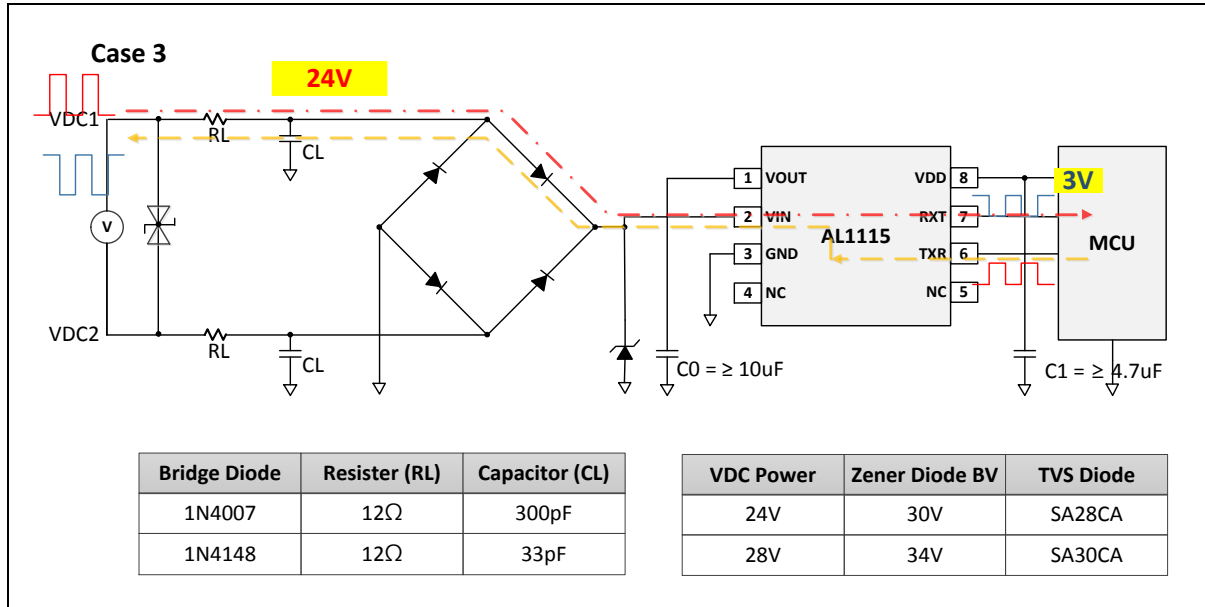

Figure 14. Application Circuit of Case 3

Table 4. Application Circuit for Case 1, 2 and 3

Bridge diode	Resistor (RL)	Capacitor (CL)	VAC power	Zener diode BV
1N4007	12Ω	300pF	24V	30V
1N4148	12Ω	33pF	28V	34V

NOTE1: The resistance RL of the bridge diode and the capacitor CL can be varied according to the communication speed environment, and the larger the capacity of VOUT and VDD, the more stable the power supply can be achieved.

NOTE2: The capacitor capacity of VDD (C1) should be less than or equal to VOUT (C0).

5 Electrical characteristics

5.1 Absolute maximum ratings

Table 5. Absolute Maximum Ratings

Parameter	Symbol	Rating	Unit
Supply voltage	VIN	-0.5 to 47	V
	VSS	-0.5 to 0.5	V
Input/ output pin voltage	VIO	-0.5 to 35	V
LDO output current	IVDD	40	mA
Ground current	IGND	40	mW
Total power dissipation	PT	300	mW
Storage temperature	Tstg	-55 to 150	°C

NOTE: Stresses above those listed under 'Absolute Maximum Ratings' may cause permanent damage to the device. This is a stress rating only and functional operation of the device at those or any other conditions above those indicated in the operation listings of this specification is not implied. Exposure above maximum rating conditions for extended periods may affect device reliability.

5.2 Recommended operating conditions

Table 6. Recommended Operating Conditions

Parameter	Symbol	Conditions	Min.	Typ.	Max.	Unit
Supply voltage	VOUT		8.5	24	42	V
Operating temperature	T _{OPR}		-40	—	85	°C

5.3 POR characteristics

Table 7. POR Characteristics

(VOUT 8.5V~42V, TA=-40°C ~ +85°C)

Parameter	Symbol	Conditions	Min.	Typ.	Max.	Unit
Reset release level ^{NOTE}		—	—	6.8	—	V

NOTE: The value is guaranteed by design and is not tested

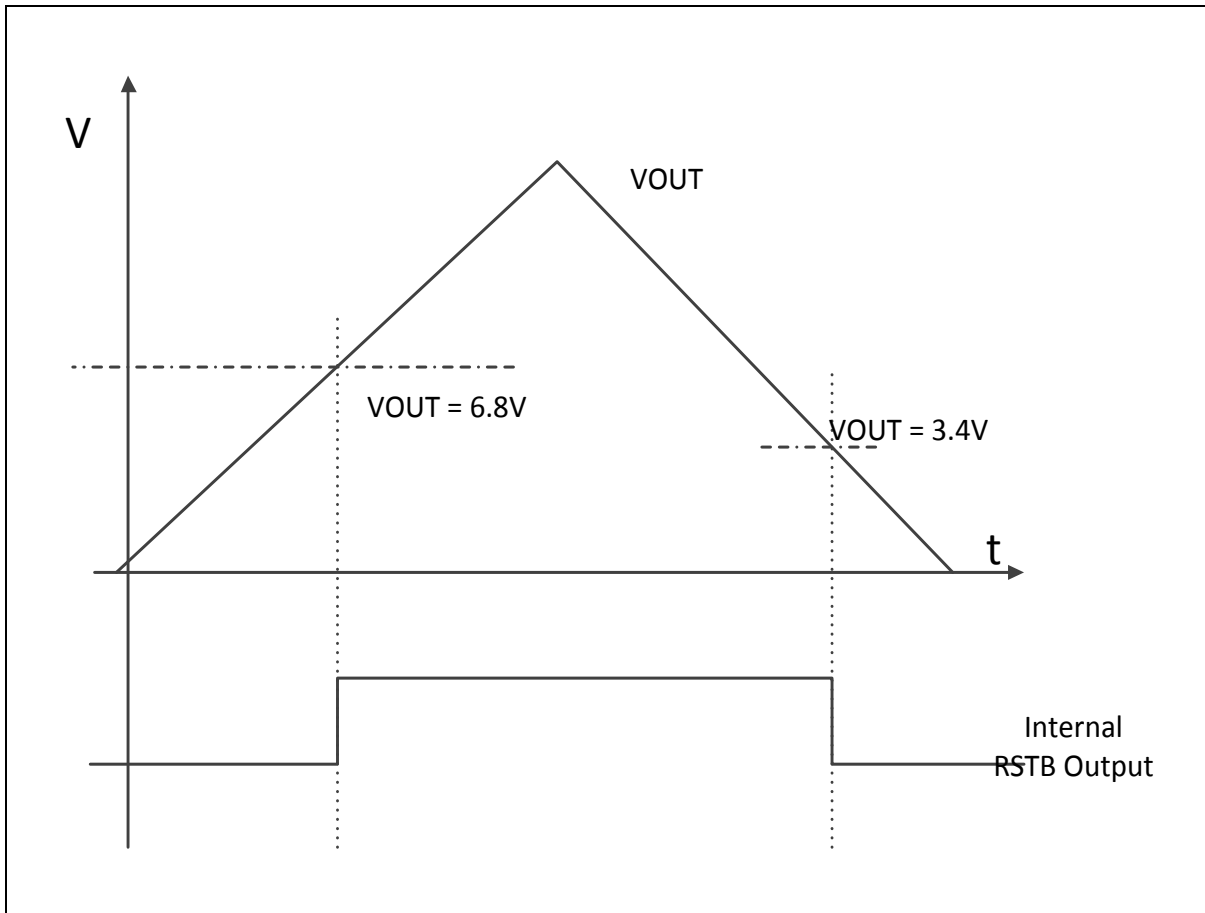

Figure 15. POR Timing Diagram

5.4 DC electrical characteristics

Table 8. DC Electrical Characteristics

(TA=25°C)

Parameter	Symbol	Conditions	Min.	Typ.	Max.	Unit
Supply voltage	VOUT	—	8.5	24	42	V
LDO output voltage	VDD	IOUT=1mA, VOUT=24V @ T= -10°C~60°C	2.91	3.0	3.09	V
	dVDD	IOUT=1mA to 5mA, VOUT=24V	—	15	20	mV
IOUT=5mA to 20mA, VOUT=24V		—	15	45		
LDO output tolerance	Vtol	VDD=3.0V VOUT=24V @ T= -10~60°C	-3		3	%
PSRR	PSRR ^{NOTE}	F=100 Hz	50			dB
TXR pull-down	IiH	VDD=3V	50	75	150	kΩ
Inrush current	IVIN1 ^{NOTE}	VIN=0V to 24V, @rise time 10ms		24	35	mA
TXR current	IVIN2	VIN=7V, VOUT=24V	60			mA
Input high voltage TXR	Vih	VDD=3V	0.8* VDD		VDD	V
Input low voltage TXR	Vil	VDD=3V	0		0.2* VDD	V
Output high voltage RXT	Voh	VDD=3V, loh=-1mA	0.8* VDD		VDD	V
Output low voltage RXT	Vol	VDD=3V, lol=1mA	0		0.2* VDD	V
VIN input voltage for RXT high	VRXH1	VOUT=8.5V	7.0		8.0	V
VOUT-VIN voltage for RXT high	VRXH2	VOUT=24V	4.0		6.0	V
Static current	IVIN	VIN=24V, VOUT=24V, TXR=0V, @T=25°C		60	90	uA

NOTE: The value is guaranteed by design and is not tested

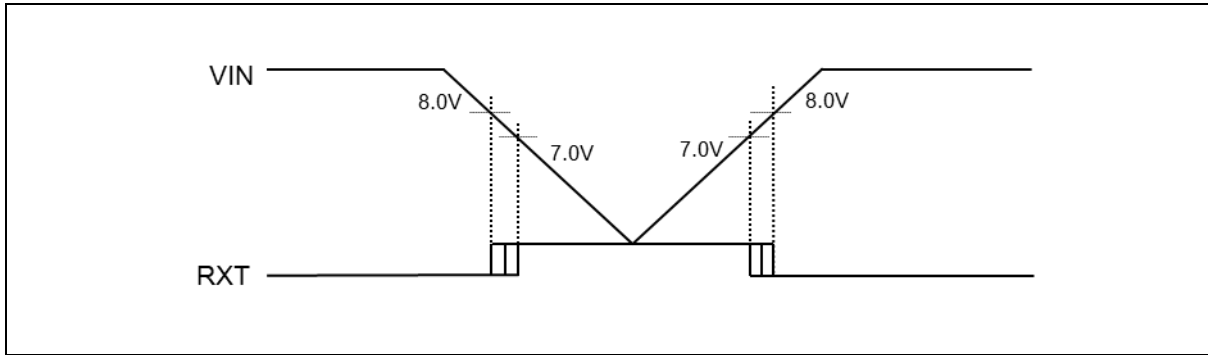

Figure 16. VIN and RXT Timing Diagram

5.5 AC electrical characteristics

Table 9. AC Electrical Characteristics

(TA=-40°C ~ +85°C)

Parameter	Symbol	Conditions	Min.	Typ.	Max.	Unit
RXT response time ^{NOTE}	trx, tfx	VOUT=24V	—	4	—	us

NOTE: The value is guaranteed by design and is not tested

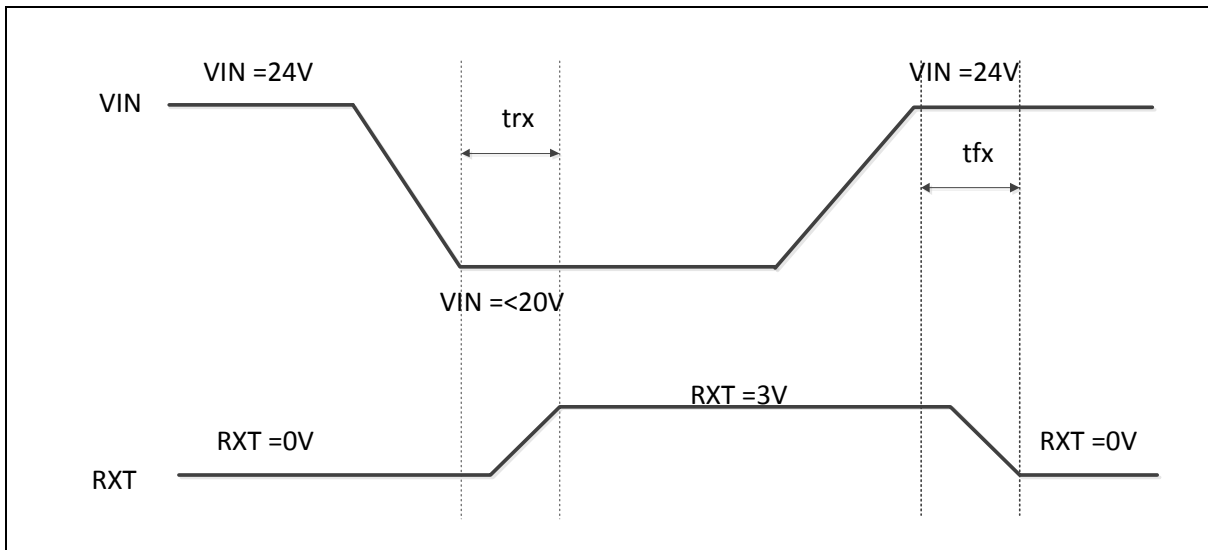

Figure 17. AC Timing Diagram

6 Package information

6.1 8 SOP package

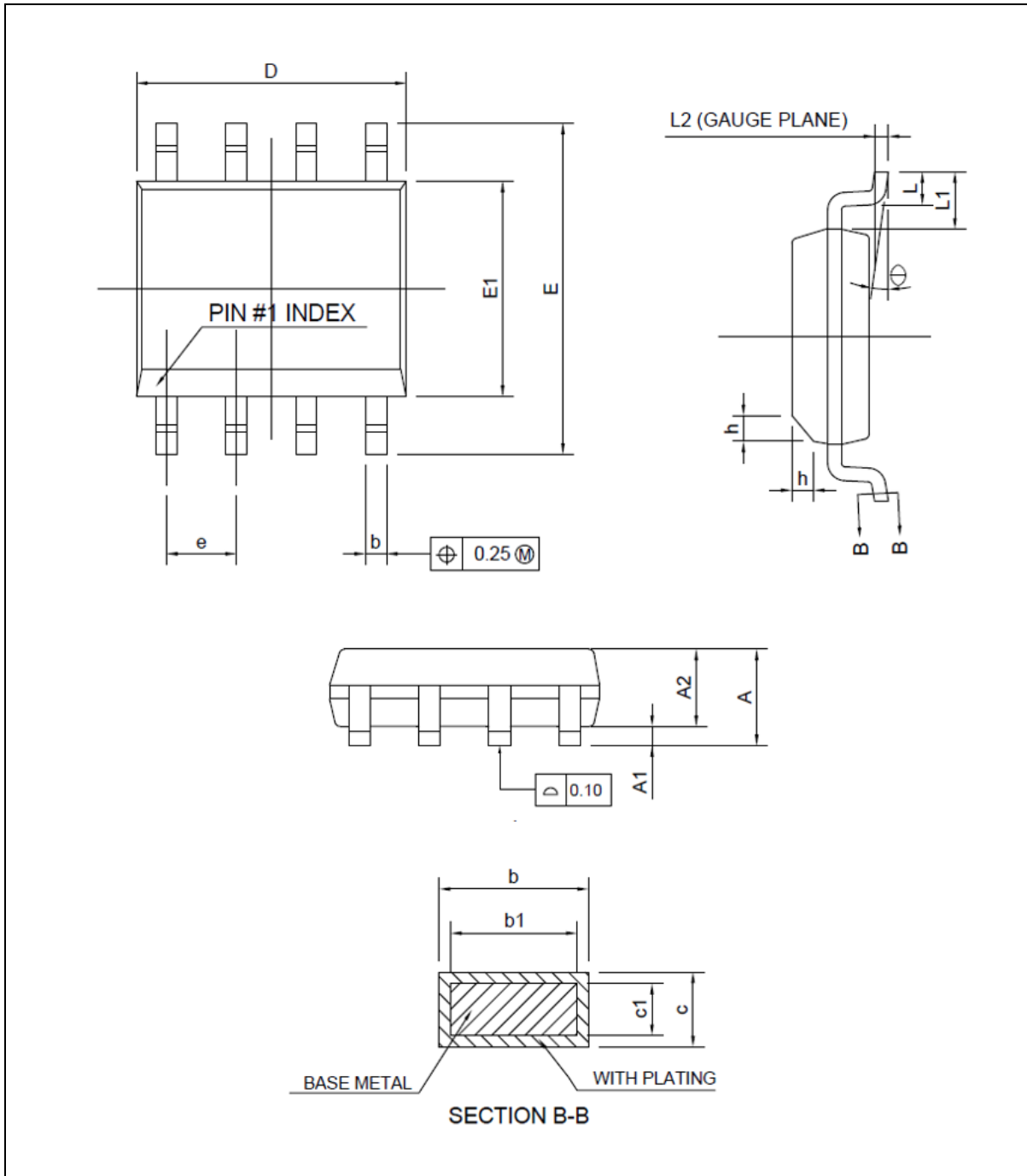

Figure 18. 8 SOP Package Outline

Table 10. 8SOP Package Mechanical Data

Symbol	Dimension (mm)		
	Min.	Nom.	Max.
A	—	—	1.75
A1	0.04	—	0.25
A2	1.25	—	—
b	0.31	—	0.51
b1	0.28	—	0.48
c	0.10	—	0.26
c1	0.10	—	0.23
D	4.70	4.90	5.10
E	5.80	6.00	6.20
E1	3.70	3.90	4.10
e	1.27 BSC		
L	0.40	—	1.27
L1	1.04 REF		
L2	0.25 BSC		
H	0.25	—	0.50
Θ	0°	—	8°

NOTES:

1. All dimensions refer to JEDEC STANDARD MS-012-AA.
2. Dimension 'D' does not include MOLD FLASH, PROTRUSIONS or GATE BURRS. MOLD FLASH, PROTRUSIONS or GATE BURRS shall not exceed 0.15 mm per end. Dimension 'E1' does not include INTERLEAD FLASH or PROTRUSION. INTERLEAD FLASH or PROTRUSION shall not exceed 0.25 mm per side.
3. Dimension 'b' does not include the DAMBAR PROTRUSION. Allowable DAMBAR PROTRUSION shall not be 0.10 mm total in excess of the 'b' dimension at maximum material condition.
4. The chamfer feature is optional. If it is not present, then a PIN #1 identifier must be located within the PIN #1 area indicated.

7 Ordering information

Table 11. AL1113/ AL1115 Ordering Information

Device name	Supply Voltage	LDO Output Voltage	Static Current	Package	Remark
AL1113HDN	8.5V~42V	3V +-3% @-10°C~60°C	MAX. 90uA @Vout =24V, 25°C	8 SOP	Separated VOUT_R, VINTx
AL1115HDN					Common VOUT_R,= VOUT VINTx =VIN

	<u>AL1113</u>	<u>H</u>	<u>D</u>	<u>N</u>	<u>(T)</u>
AL111x Family Name & Pin					
3	Selected Metal option AL1113				
5	Selected Metal option AL1115				
Pin count					
H	8PIN				
Package Type					
D	SOP				
Bonding Type					
N	CU-wire				
none	AU-wire				
Packing					
(T)	Tape & Reel				

NOTE: For more information on any aspect of this device, please contact your nearest distributor or ABOV sales office.

Figure 19. AL1113/AL1115 Series Numbering Nomenclature

Revision history

Date	Version	Description
2019.12.18	1.00	First creation
2020.01.07	1.01	Updated LDO temperature condition in DC characteristics Updated current consumption temperature condition in DC characteristics Updated RF-EMS Passed in feature Updated typo. 3.1 Pinout Updated logic block diagram
2020.03.23	1.10	Updated Block diagram AL1115 Updated ULVO reset level to POR reset Updated DC characteristics Supply voltage is changed VIN to VOUT
2020.05.18	1.11	Updated NOTE2 in Application circuit Updated LDO specification, +/-3%@25°C to -10°C~60°C
2020.05.21	1.20	Updated Static current 80uA to 90uA
2020.06.08	1.21	Updated Table.1 and Table 11
2020.06.09	1.22	Updated Figure 7 and Figure 8. 8 SOPN to 8 SOP

Korea

Regional Office, Seoul
R&D, Marketing & Sales
8th Fl., 330, Yeongdong-daero,
Gangnam-gu, Seoul,
06177, Korea

Tel: +82-2-2193-2200
Fax: +82-2-508-6903
www.abovsemi.com

Domestic Sales Manager

Tel: +82-2-2193-2206
Fax: +82-2-508-6903
Email: sales_kr@abov.co.kr

HQ, Ochang
R&D, QA, and Test Center
93, Gangni 1-gil, Ochang-eup,
Cheongwon-gun,
Chungcheongbuk-do,
28126, Korea

Tel: +82-43-219-5200
Fax: +82-43-217-3534
www.abovsemi.com

Global Sales Manager

Tel: +82-2-2193-2281
Fax: +82-2-508-6903
Email: sales_gl@abov.co.kr

China Sales Manager

Tel: +86-755-8287-2205
Fax: +86-755-8287-2204
Email: sales_cn@abov.co.kr

ABOV Disclaimer**IMPORTANT NOTICE – PLEASE READ CAREFULLY**

ABOV Semiconductor ("ABOV") reserves the right to make changes, corrections, enhancements, modifications, and improvements to ABOV products and/or to this document at any time without notice. ABOV does not give warranties as to the accuracy or completeness of the information included herein. Purchasers should obtain the latest relevant information of ABOV products before placing orders. Purchasers are entirely responsible for the choice, selection, and use of ABOV products and ABOV assumes no liability for application assistance or the design of purchasers' products. No license, express or implied, to any intellectual property rights is granted by ABOV herein. ABOV disclaims all express and implied warranties and shall not be responsible or liable for any injuries or damages related to use of ABOV products in such unauthorized applications. ABOV and the ABOV logo are trademarks of ABOV. All other product or service names are the property of their respective owners. Information in this document supersedes and replaces the information previously supplied in any former versions of this document.

© 2020 ABOV Semiconductor – All rights reserved