

- CESIGN -

# **BPIC(Battery Protection IC)**

# 1 Battery Protection IC Overview

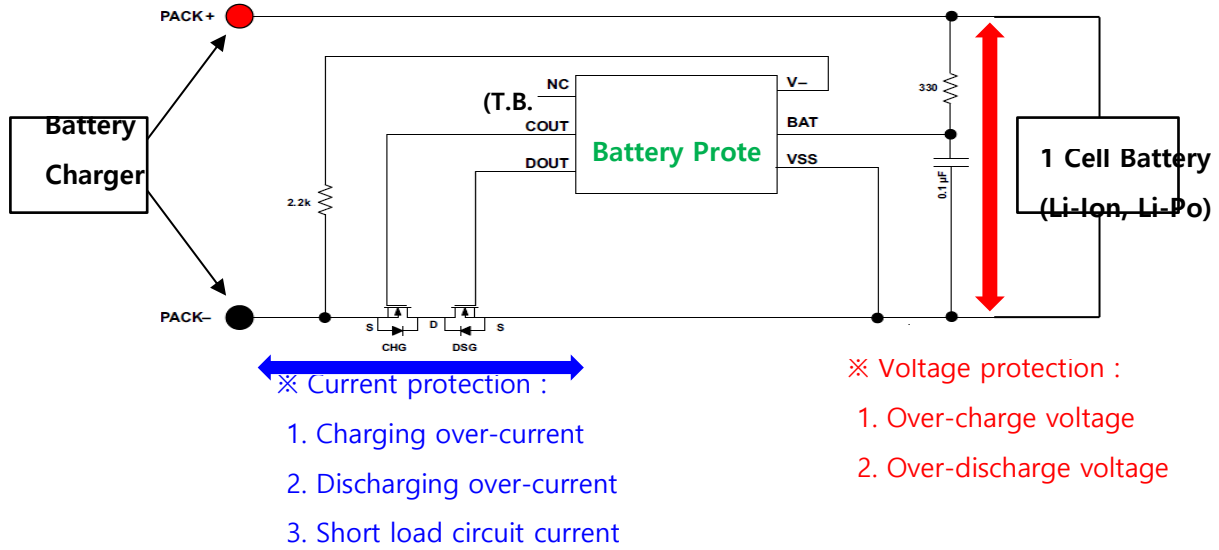

Figure 1 Block Diagram of BPIC)

